



SyQuest
TECHNOLOGY

SQ555

OEM



**TECHNICAL
REFERENCE MANUAL**



SyQuest

SQ555 REMOVABLE CARTRIDGE DISK DRIVE

OEM TECHNICAL REFERENCE MANUAL

MANUAL CONFIGURATION

The table below lists all changes issued for this SQ555 OEM
Technical Reference Manual July 1989 edition to the date shown.

PAGES	DATE	REVISION ID
x, 5-2, A-2, A-3, B-1, 5-3	October 1989 June 1990	B C

■ : Revision Bar. Indicates changes to previous revision(s).

Copyright 1989 SyQuest Technology
All Rights Reserved

Information provided herein is copyrighted. This document may not, in whole or part, be copied, photographed, translated, or reproduced in any form or by any means, electrical or mechanical, without prior written permission from SyQuest Technology.

**SQ555
OEM TECHNICAL REFERENCE MANUAL
TABLE OF CONTENTS**

OVERVIEW

I.	INTRODUCTION	x
II.	SCOPE	x
III.	KEY FEATURES	x

SECTION

1.0 SQ555 INSTALLATION

1.1	WHAT YOU NEED TO INSTALL THE SQ555	1-1
1.2	INSTALLING THE DISK DRIVE	1-2
1.2.1	Shipping Contents	1-2
1.2.2	Preparing The Drive	1-3
1.2.3	Preparing The Computer	1-9
1.2.4	Inserting The Drive And Connecting The Cables	1-10
1.3	PREPARING A CARTRIDGE FOR USE	1-12

2.0 SQ555 OPERATION GUIDE

2.1	BEFORE YOU BEGIN	2-1
2.2	HANDLING INSTRUCTIONS	2-1
2.3	OPERATING SYSTEM SOFTWARE	2-2
2.4	INSERTING AND REMOVING THE SQ400 DISK CARTRIDGE	2-2
2.4.1	Inserting The Cartridge	2-2
2.4.2	Removing The Cartridge	2-4
2.5	FORMATTING THE CARTRIDGE	2-4
2.6	WRITE-PROTECTING THE SQ400 DISK CARTRIDGE	2-5

3.0 SQ555 FUNCTIONAL CHARACTERISTICS/OVERVIEW

3.1	GENERAL OPERATION	3-1
3.2	FUNCTIONAL OVERVIEW	3-1
3.3	SCSI CONTROLLER	3-2
3.3.1	Bus Arbitration	3-2
3.3.2	Handshaking And Termination	3-2

3.4	DISK CONTROLLER	3-2
3.4.1	Programmable Storage Controller (PSC)	3-2
3.4.2	Data Conversion, Direction, And Type	3-3
3.4.3	Track And Sector Formatting	3-3
3.5	DUAL PORT BUFFER CONTROLLER	3-3
3.5.1	Buffer RAM Management	3-3
3.5.2	Data Management	3-3
3.5.3	Conflict Resolution And SCSI Bus Arbitration	3-3
3.6	BUFFER RAM	3-3
3.7	MICROCONTROLLER	3-4
3.8	ENCODER/DECODER	3-4
3.9	MECHANICAL COMPONENTS	3-4
4.0	SQ400 DISK CARTRIDGE	
4.1	OVERVIEW	4-1
4.2	DISK INFORMATION PATTERNS	4-1
4.2.1	Servo Address Patterns	4-1
4.2.2	Position Patterns	4-1
4.2.3	Sector Format	4-1
4.3	TRACK ASSIGNMENT	4-1
4.3.1	Data Format and Flaw Assignment	4-1
4.3.2	System Tracks	4-1
5.0	SQ555 DIAGNOSTICS	
5.1	OVERVIEW	5-1
5.1.1	Power-Up Test	5-1
5.1.2	Performance Diagnostic Tests	5-1
5.1.3	The Procedure To Install The Diagnostic Test Jumpers And To Perform The Self Test Routine	5-2
5.1.4	Requirements For Diagnostic Tests To Run Properly	5-2
5.1.5	Power Up & Performance Diagnostic Test Error Reporting ..	5-3

6.0 SCSI IMPLEMENTATION

6.1	OVERVIEW	6-1
6.2	SCSI COMMAND SET	6-3
6.2.1	Test Unit Ready Command Operation Code: 00H	6-4
6.2.2	Rezero Unit Command Operation Code: 01H	6-4
6.2.3	Request Sense Command Operation Code: 03H	6-5
6.2.3.1	Non-Extended Sense	6-6
6.2.3.2	Extended Sense	6-7
6.2.4	Format Unit Command Operation Code: 04H	6-10
6.2.5	Reassign Blocks Command Operation Code: 07H	6-15
6.2.6	Read Command Operation Code: 08H	6-17
6.2.7	Write Command Operation Code: 0AH	6-18
6.2.8	Seek Command Operation Code: 0BH	6-18
6.2.9	Read Usage Counters Command Operation Code: 11H ...	6-19
6.2.10	Inquiry Command Operation Code: 12H	6-21
6.2.11	Mode Select Command Operation Code: 15H	6-24
6.2.12	Reserve Command	6-35
6.2.13	Release Command	6-35
6.2.14	Mode Sense Command Operation Code: 1AH	6-36
6.2.15	Start/Stop Command Operation Code: 1BH	6-40
6.2.16	Receive Diagnostic Results Command Operation Code: 1CH	6-41
6.2.17	Send Diagnostic Command Operation Code: 1DH	6-41
6.2.18	Prevent Allow Medium Removal Command Operation Code: 1EH	6-42
6.2.19	Read Capacity Command Operation Code: 25H	6-43
6.2.20	Extended Read Command Operation Code: 28H	6-45
6.2.21	Extended Write Command Operation Code: 2AH	6-46
6.2.22	Extended Seek Command Operation Code: 2BH	6-47
6.2.23	Verify Command Operation Code: 2FH	6-48
6.2.24	Read Defect Data Command Operation Code: 37H	6-49
6.2.25	Write Buffer Operation Code: 3BH	6-51
6.2.26	Read Buffer Operation Code: 3CH	6-53
6.3	SENSE KEY AND ERROR CODE DESCRIPTORS	6-56
6.3.1	Sense Keys	6-56
6.3.2	Error Codes	6-57

7.0 SQ555 MAINTENANCE

7.1	CLEANING REQUIREMENT	7-1
7.2	CLEANING EQUIPMENT	7-1
7.2.1	The C-CART kit	7-2
7.3	CLEANING PROCEDURE	7-2
7.3.1	C-FOAM	7-2

APPENDICES

A.	TECHNICAL SPECIFICATIONS	A-1
B.	ENVIRONMENTAL REQUIREMENTS	B-1
C.	READ/WRITE TIMING DIAGRAMS	C-1
D.	SCSI ELECTRICAL SPECIFICATION	
D.1	SCSI BUS SIGNALS	D-1
D.1.2	Signal Characteristics	D-2
D.2	SCSI SIGNAL SOURCES	D-2
D.3	SCSI BUS TIMING	D-3
D.3.1	Arbitration Delay	D-3
D.3.2	Assertion Period	D-3
D.3.3	Bus Clear Delay	D-3
D.3.4	Bus Free Delay	D-3
D.3.5	Bus Set Delay	D-4
D.3.6	Bus Settle Delay	D-4
D.3.7	Cable Skew Delay	D-4
D.3.8	Data Release Delay	D-4
D.3.9	Deskew Delay	D-4
D.3.10	Reset Hold Time	D-4
D.3.11	Selection Abort Time	D-4
D.3.12	Selection Timeout Delay	D-4

SQ555 OEM TECHNICAL REFERENCE MANUAL

LIST OF FIGURES

1-1.	SQ555 Physical Interface	1-3
1-2.	Connecting The Unit Select Jumper	1-4
1-3.	Removing The Terminating Resistor Pack	1-6
1-4.	Mounting Rails	1-7
1-5.	SQ555 Physical Dimensions	1-8
1-6.	Selecting A 5.25 Inch Half-Height Slot	1-9
1-7.	Connecting The SCSI Cable	1-9
1-8.	Attaching The Ground Lug Connector	1-10
1-9.	Power Connector And Pin Assignments	1-11
1-10.	Connecting The Power Cable	1-11
2-1.	Inserting The Cartridge	2-2
2-2.	Spinning Up The Disk	2-3
2-3.	The LEDs	2-3
2-4.	Removing The Cartridge	2-4
2-5.	Cartridge Write-Protect Cylinder	2-5
3-1.	Drive Electronics Block Diagram	3-1
3-2.	Mechanical Components	3-4
7-1.	Spindle Motor Hub	3-3
7-2.	C-Foam Installation	3-3
7-3.	Cleaning Fluid Application Procedure	3-3
7-4.	C-CART Installation Procedure	3-3
C-1.	Read Timing Diagram	C-1
C-2.	Write Timing Diagram	C-3

LIST OF TABLES

5-1.	LED Error Reporting Table	5-3
6-1.	SCSI Signal Lines	6-2
6-2.	SQ555 ANSI Commands Description	6-3
6-2-1.	Test Unit Ready Command	6-4
6-2-2.	Rezero Unit Command	6-4
6-2-3.	Request Sense Command	6-5
6-2-3-1.	Non-Extended Sense Data Format	6-6
6-2-3-2.	Extended Sense Data Format	6-7

6-2-4.	Format Unit Command	6-10
6-2-4-1.	Format Unit Command Variations	6-11
6-2-4-2.	Defect List – Block Format	6-12
6-2-4-3.	Defect List – Block Format When Using Manufacturing Defect List	6-13
6-2-4-4.	Defect List – Physical Sector Format	6-14
6-2-5.	Reassign Blocks Command	6-15
6-2-5-1.	Reassign Blocks Defect List	6-16
6-2-6.	Read Command	6-17
6-2-7.	Write Command	6-18
6-2-8.	Seek Command	6-18
6-2-9.	Read Usage Counters Command	6-19
6-2-9-1.	Usage Counter Format	6-20
6-2-10.	Inquiry Command	6-21
6-2-10-1.	Inquiry Data	6-22
6-2-11.	Mode Select Command	6-24
6-2-11-1.	Mode Select Header	6-25
6-2-11-2.	Page Codes	6-27
6-2-11-3.	Operating Parameters	6-27
6-2-11-4.	Error Recovery Parameters	6-28
6-2-11-5.	Table Summary All Valid Modes of Operation ...	6-30
6-2-11-6.	DMA Parameters	6-31
6-2-11-7.	Format Parameters (Default Only)	6-32
6-2-11-8.	Geometry Parameters (Default Only)	6-34
6-2-11-9.	Vendor/Product Identification	6-35
6-2-14.	Mode Sense Command	6-36
6-2-14-1.	Page Codes	6-38
6-2-14-2.	Page Code Field Bit 7 and 6 Byte 2 of The CDB	6-38
6-2-15.	Start /Stop Commands	6-40
6-2-16.	Receive Diagnostic Results Command	6-41
6-2-17.	Send Diagnostic Command	6-41
6-2-18.	Prevent/Allow Medium Removal Command	6-42
6-2-19.	Read Capacity Command	6-43
6-2-19-1.	Read Capacity Data	6-44
6-2-20.	Extended Read Command	6-45
6-2-21.	Extended Write Command	6-46

6-2-22. Extended Seek Command	6-47
6-2-23. Verify Command	6-48
6-2-24. Read Defect Data Command	6-49
6-2-25. Write Buffer Command	6-51
6-2-25-1. Write Buffer Header	6-52
6-2-26. Read Buffer Command	6-53
6-2-26-1. Read Buffer Header	6-54
6-2-26-2. Read Buffer Descriptor	6-55
6-3-1. Sense Keys (0-7)	6-56
6-3-2. Additional Sense Codes	6-57
6-3-2. Additional Sense Codes (continued)	6-58
A-1. Technical Specifications	A-1
B-1. Environmental Requirements	B-1
C-1. Read Timing Diagram Timing Transients	C-2
C-2. Write Timing Diagram Timing Transients	C-4
D-1. SCSI Bus Signals	D-1
D-1-2. Signal Levels	D-2
D-2. Signal Sources	D-2

OVERVIEW

I. INTRODUCTION

The SQ555 is a high performance 5.25 inch 44 Megabytes (formatted) Cartridge Disk Drive with the Small Computer System Interface (SCSI) and utilizing the Common Command Set (CCS).

II. SCOPE

This document describes the basic procedures for installation of the SQ555 Disk Drive and the SQ400 Cartridge preparation for use.

III. KEY FEATURES

- Removable Cartridge Media
- 44 Megabyte (formatted) Storage Capacity per Cartridge
- Unlimited Off-Line Storage
- Fully Integrated SCSI Controller with the CCS Required Commands
- 20 Millisecond Average Seek Time
- Industry Standard Half-Height 5.25 inch Form Factor
- 30,000 Hour MTBF
- Data Transfer Rate of up to 1.25 Megabytes per Second
- 8K Data Buffer
- Read/Write Operations with 1:1 Interleave
- Automatic Error Correction and Retries
- Transparent Defect Management with Track and Sector Sparing
- Self-Diagnostics at Power Up
- Rugged Hard Disk Cartridges

Notice to Users

SyQuest Technology makes no representations or warranties with respect to the contents hereof, and specifically disclaims any implied warranties of merchantability or fitness for any purpose.

SyQuest Technology reserves the right to revise this document and to make changes from time to time without obligations to notify any person of such revisions and changes.

While every effort has been made to ensure that the information provided herein is correct, please notify us in the event of any errors. Please write your comments, your name, address and telephone number (include name and P/N of the document) and mail it to:

SyQuest Technology
47923 Warm Springs Blvd.
Fremont, CA 94539-7494

Attention: Technical Publications

SQ555 – Installation

SECTION 1

SQ555 INSTALLATION

The SyQuest SQ555 Winchester disk drive is easy to install. This section gives you basic procedures to install the SQ555 in any 5.25 inch half-high disk drive housing in your computer. It also describes how to prepare your SQ400 disk cartridge for use.

1.1 WHAT YOU NEED TO INSTALL THE SQ555

In addition to the SQ555 disk drive unit and the SQ400 cartridge, there are several other items you will need to complete the installation process and begin using the disk drive:

- Host Bus Adapter (not required for computers with a built-in SCSI port). The Host Bus Adapter is a card installed in one of your computer expansion slots. You connect the SQ555 to this adapter. Follow the instructions provided by the host adapter manufacturer to install it in your computer. To purchase an IBM PC XT/AT or compatible Host Bus Adapter, contact SyQuest or any authorized SyQuest distributor.
- SCSI cable to connect the Host Bus Adapter to the SQ555. This cable is supplied with the Host Bus Adapter.
- Ground lug connector cable. This cable is supplied with the drive.
- SQ400 disk cartridge. The cartridge is purchased separate from the drive; contact SyQuest or any authorized SyQuest distributor.
- Mounting rails, required for IBM PC AT computers and some compatibles. These rails attach to the sides of the SQ555. A mounting rail kit is supplied with the drive.
- Device Driver software
A special Device Driver software program is required to support cartridge interchangeability, and to allow addressing beyond two physical drives.

The Device Driver Software program for SyQuest approved "standard" Host Bus Adapters for IBM PC XT/AT or compatible machines and PC DOS/MS DOS is contained on the SQ555 Utility Software Diskette P/N 30116-001; supplied with your Host Bus Adapter. Use the installation instruction information supplied in the SyQuest Removable Cartridge Preparation and Utility Software Users Manual P/N 58078-001. The INSTALL.DOC program provided on the SyQuest-SQ555 Utility Software diskette provides additional information to install the Device Driver on your computer.

CAUTION

This Device Driver allows the system to recognize a cartridge change. Using the SQ555 disk drive without an appropriate Device Driver may cause loss of data. (This exposure occurs only when cartridges are changed while the system is powered on and the device driver is not installed).

SyQuest provides the removable cartridge Device Driver SYQ55.SYS, at no cost, to support several different Host Bus Adapters. Contact any authorized SyQuest distributor or SyQuest directly for additional information.

SQ555 – Installation

1.2 INSTALLING THE DISK DRIVE

The SQ555 can be installed into any computer that supports SCSI or has space for a SCSI Host Bus Adapter. The exact procedures and mounting hardware required to install the SQ555 in your computer depend upon the configuration of your 5.25 inch half-height drive mount slot and your Host Bus Adapter or SCSI port. The procedures given here are meant as a general guide to installation; therefore, you will have to adapt them to your specific computer configuration.

The SQ555 can be installed in the following computers.

- IBM PC, XT, AT, PS/2 (Model 30) or compatibles with MS or PC DOS

In addition to the SQ555, you must also have a SQ555 compatible Host Bus Adapter and the Device Driver software to support cartridge interchange.

- APPLE COMPUTER SYSTEMS

The SQ555 can be attached directly into the APPLE external SCSI port. User provisions must be made for external DC power source and the SCSI Interface cable. You should also have an appropriate SCSI Driver Installer to support cartridge interchange.

1.2.1 Shipping Contents

Open the package containing your SQ555 disk drive and remove its contents:

- SQ555 disk drive
- SQ555 Installation and Operation Guide
- Ground lug connector cable
- Mounting Rail Kit

If any items are missing or if you have questions concerning your package contents, contact SyQuest or your distributor.

SQ555 – Installation

1.2.2 Preparing The Drive

- a. Identify the power connector, unit select jumpers, manufacturing test points, ground lug connector, terminating resistor, and SCSI connector on the back of the SQ555 disk drive. See FIGURE 1-1.

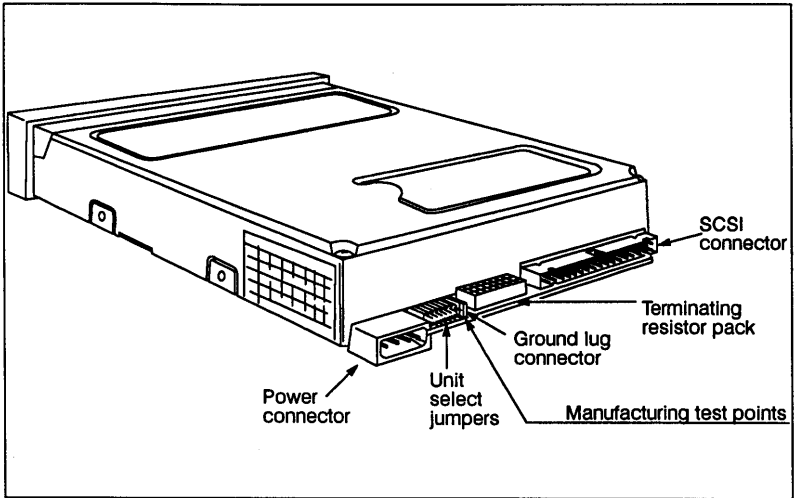

Figure 1-1. SQ555 Physical Interface

SQ555 – Installation

- b. SCSI ID Jumper – install as required.

No jumper is required if you have only one SQ555 attached to your Host Bus Adapter. (preset for ID "0")

Select a number to use as the SCSI ID number for your unit. You can set the SQ555 to any ID number between 0 (the present ID) and 7, but be sure that the number you choose is not already assigned to another device on the same SCSI bus. Once you have set the ID number you want to use, install the ID jumpers across the pairs of pins indicated in Figure 1.2. **NEVER INSTALL A JUMPER ACROSS DIFFERENTLY LABELED PINS (FOR EXAMPLE, ROW "A" PINS TO ROW "B" PINS).**

NOTE: Do not confuse the Manufacturing Test Points labeled "X" with the ID Select Pins. These manufacturing test points are incorporated on Engineering Level 6 drives and up only.

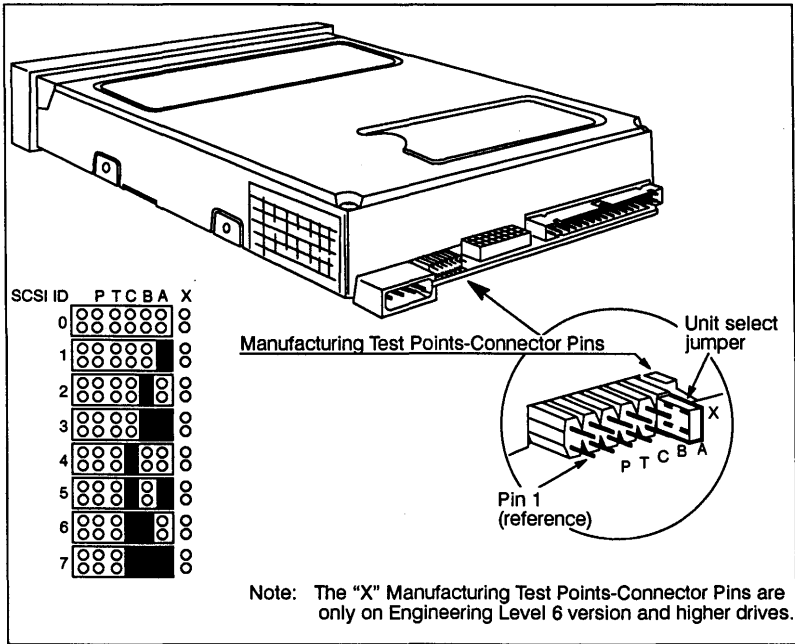

Figure 1-2. Connecting the Unit Select Jumper

SQ555 – Installation

NOTE: Only one ID unit select jumper is provided with the drive. Additional jumpers can be ordered from SyQuest or any authorized SyQuest distributor.

NOTE: The "X" Manufacturing Test Points-Connector Pins are only on Engineering Level 6 and higher drives.

NOTE: The ID number assigned to the SQ555 is used to identify the drive on the SCSI bus. It does not have any effect on non-SCSI device numbers used by other devices in your computer system. For instance, an internal ST506 hard disk may have an ID number that is numerically the same as the one you select for your SQ555; the two numbers have no effect on each other, since they are assigned to devices on different buses. Only SCSI devices that are on the same SCSI bus have ID numbers that affect each other. All SCSI devices attached to the SCSI bus require a unique ID number.

If you have installed more than one Host Bus Adapter in your system the number of SCSI buses you have will be the same as the number of your Host Bus Adapters. This means that you can duplicate SCSI ID numbers among devices. For example, you can have two devices with ID number 0, so long as they are on different buses, that is, connected to different Host Bus Adapters.

SQ555 – Installation

c. SCSI Terminating Resistor Pack

Determine whether or not you will need the terminating resistor pack. (this pack comes already installed from SyQuest)

If the SQ555 is the last or only SCSI device in the series of devices connected to your computer bus, you **MUST** have the resistor pack installed to provide termination on a SCSI bus.

If the SQ555 is not the **LAST** or **ONLY** device, you **MUST** remove the resistor pack. The SCSI ID number assigned to your device does not matter; it is the physical location in the device daisy-chain that determines the need for terminating resistors. Only the last physical device on a SCSI Bus needs a Terminating Resistor Pack.

NOTE: If you need to reinstall the terminating resistor pack, make sure that the pin 1 (with black dot) is inserted into the correct pin 1 socket. See FIGURE 1-3.

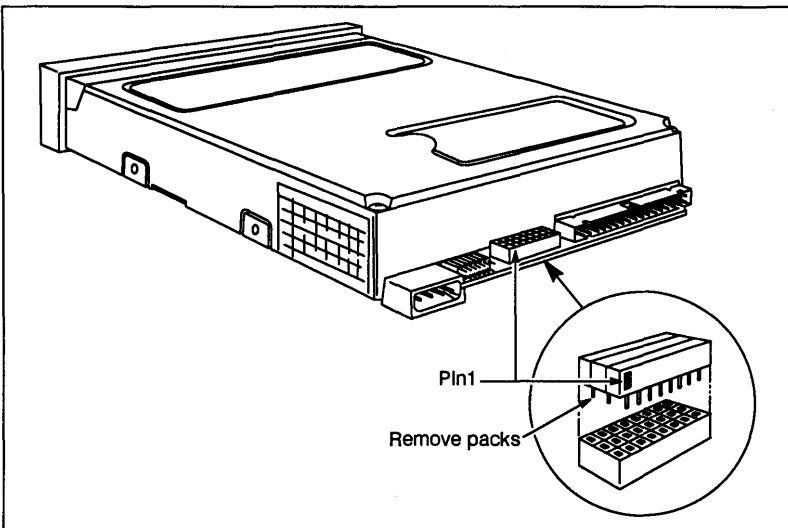

Figure 1-3. Removing the Terminating Resistor Pack

SQ555 – Installation

- d. If you have an IBM PC AT computer or compatible, you must attach the narrow mounting rails to the drive using the screws provided. The mounting rails should be attached so that the narrow part of the rail faces the back of the drive. See FIGURE 1-4.

NOTE: Some of the compatibles may only need mounting screws.

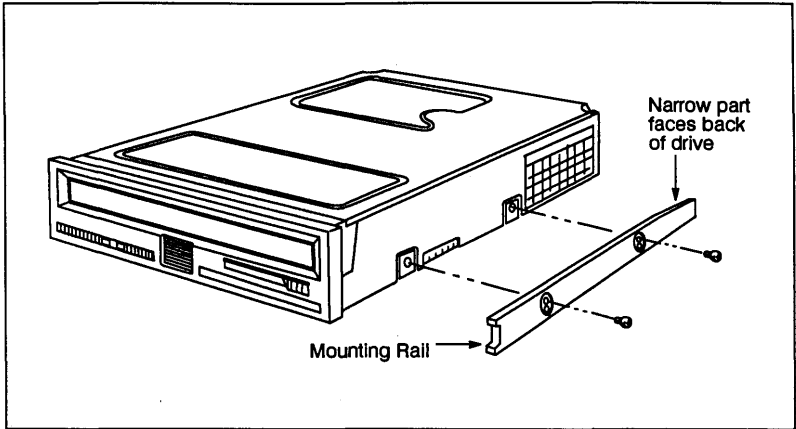

Figure 1-4. Mounting Rails

SQ555 – Installation

- e. The SQ555 approved mounting configuration is on either side or horizontal with the PCB down. Eight mounting holes are provided in the drive chassis. These holes accept 6-32 machine screws. See FIGURE 1-5.

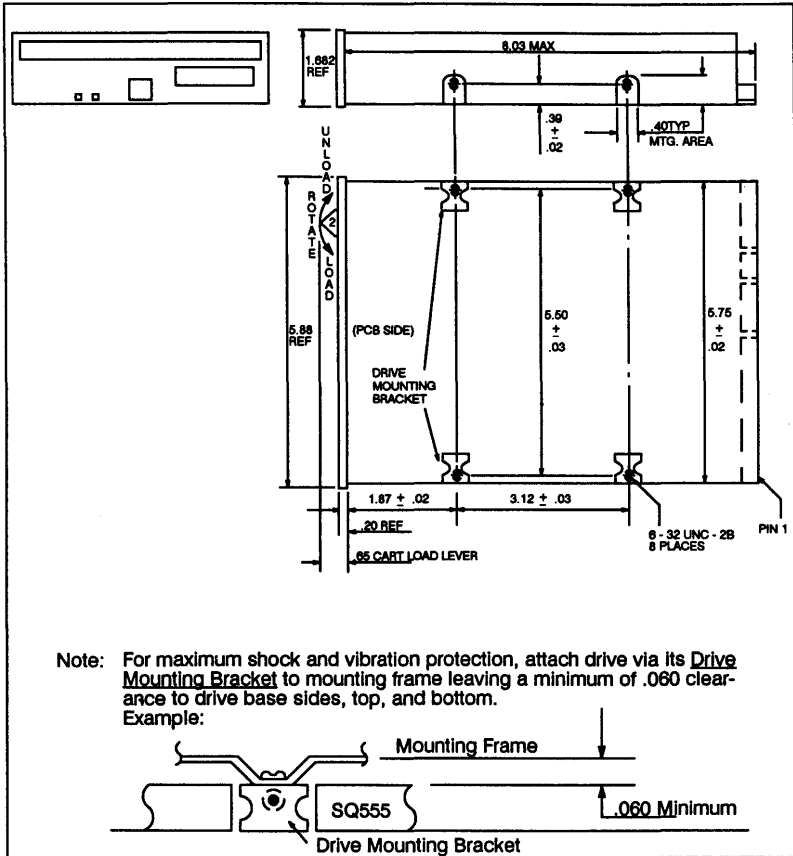

Figure 1-5. SQ555 Physical Dimensions

SQ555 – Installation

1.2.3 Preparing The Computer

- a. Turn off the power to the computer.
- b. Remove the cover of your computer system unit. Follow the instructions in the installation or operations manual that comes with your computer.
- c. Select the 5.25 inch half-height slot in which to install your SQ555 and remove any retaining hardware already installed in the drive slot. You can install the drive in any available slot; however, SyQuest recommends that you mount the SQ555 in the bottom slot. Also, when you select a slot, be sure to allow enough space for air flow along the printed-circuit board assembly. For example, mount the SQ555 next to a floppy disk drive, not another fixed disk. Some standard configurations are shown in FIGURE 1-6.

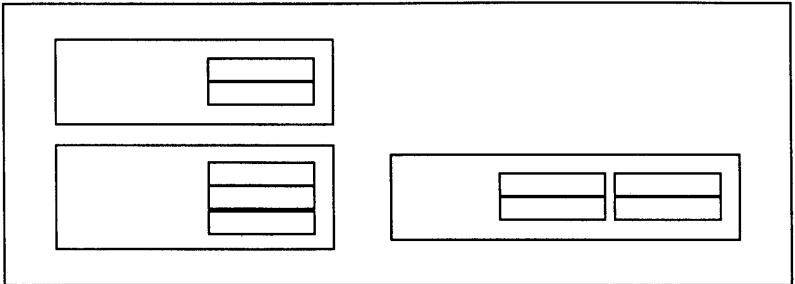

Figure 1-6. Selecting a 5.25 inch Half-Height Slot

- d. Depending on the accessibility of the slot you want to use, you may need to remove adjacent cables or drives. If this is necessary, do so now.
- e. Connect the 50-pin SCSI cable to the SCSI connector on the drive. Make sure you align pin 1 of the connector with pin 1 (color stripe end) of the cable. See FIGURE 1-7.

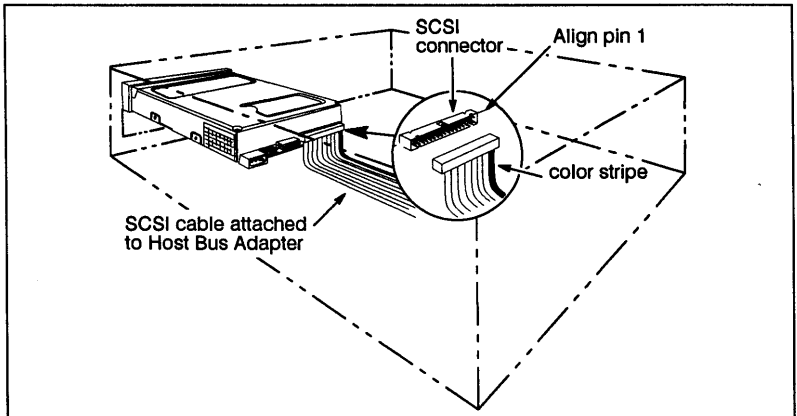

Figure 1-7. Connecting the SCSI Cable

SQ555 – Installation

1.2.4 Inserting The Drive And Connecting The Cables

The following are general instructions for installing your SQ555 disk drive in most 5.25 inch half-height disk drive housings. Cabling requirements will differ from computer to computer.

- a. Slide the drive into the slot you selected and reinstall any retaining hardware you removed earlier.

NOTE: When you install the drive, be sure that you use all four mounting screws and that the drive does not touch any of the computer's internal components.

- b. The SQ555 uses a 50 conductor interface cable, and a 50 pin connector, consisting of two rows of 25 male pins on 100 mil centers. The cable characteristic impedance is 132 ohms +/-10% with a minimum conductor size of 28 AWG. The maximum cable length is 6.0 meters (19.68 ft).
- c. Connect the free end of the SCSI cable to the connector assembly provided with your Host Bus Adapter. Make sure you align pin 1 of the connector with pin 1 of the cable.
- d. Connect the ground lug connector to the SQ555 and the chassis of the computer. See FIGURE 1-8.

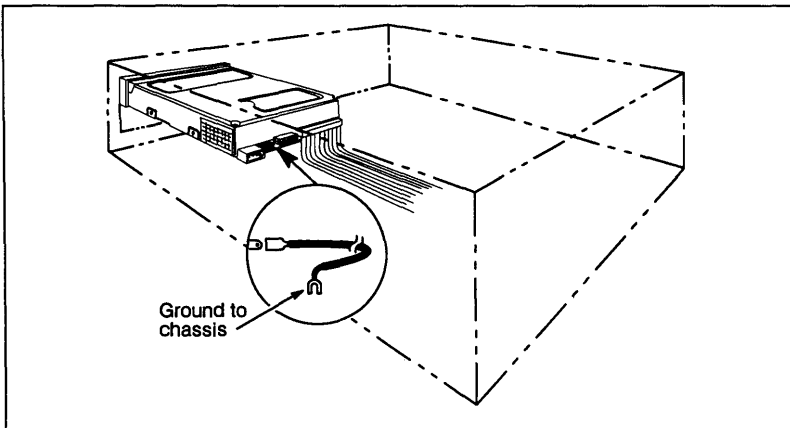

Figure 1-8. Attaching the Ground Lug Connector

SQ555 – Installation

- e. The SQ555 has a 4 pin DC power connector mounted on the PCB. The pins are numbered as shown. (Figure 1-9.). The recommended mating connector is AMP P/N 1-480424-0 utilizing AMP pins P/N 350078-4.

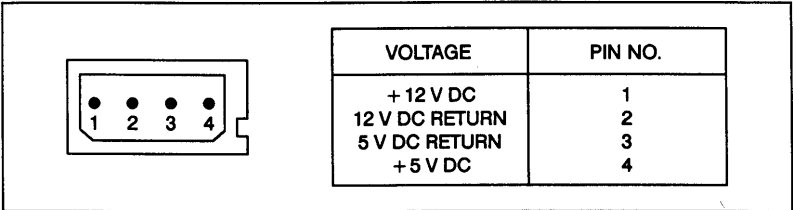

Figure 1-9. Power Connector and Pin Assignments

- f. Connect the four-conductor DC internal power cable in your computer to the power connector on the drive. See Figure 1-10. If you need a power cable, see your distributor.

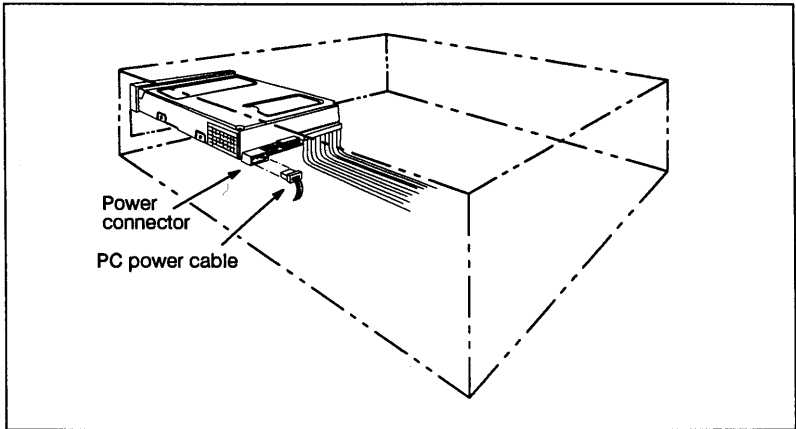

Figure 1-10. Connecting the Power Cable

- g. Replace the system unit cover.

SQ555 – Installation

1.3 PREPARING A CARTRIDGE FOR USE

Before you can use an SQ400 cartridge, you must initialize it for use with your operating system. The procedures for formatting or initializing hard disk drives differ among operating systems; therefore, you must refer to your operating system manual or to the reference manual for the Host Bus Adapter you are using for specific instructions.

The procedure to perform this initialization, (if you are using an IBM compatible system), is easily done through the software utilities supplied on the SyQuest SQ555 Utility Software Diskette. The following document defines the process of the SQ400 Cartridge Preparation and should be available for reference:

Removable Cartridge Preparation and Utility Software "User's Manual," P/N 58078-001.

In addition to the above document, the following document will also serve as a valuable reference material:

Installation and Operation Guide "Users Manual", P/N 58080-001

NOTE: This document in one of its sections provides detailed information on the SQ400 Cartridge Preparation.

If you do not have a SyQuest approved Host Bus Adapter and Device Driver, or the SyQuest SQ555 Utility Software diskette, you can initialize the cartridge using DOS. General instructions for preparing the cartridge by using DOS "FDISK" and "FORMAT" are described in your DOS reference manual. In addition to the DOS manual, the following SyQuest document may also serve as valuable reference material:

Removable Cartridge Preparation via DOS, P/N 58081-001.

NOTE: It is advisable to use the software utilities supplied by SyQuest and/or alternate approved utilities for the Host Bus Adapter being utilized.

If you are using an APPLE computer system, you must use the Apple System manual or your Disk Drive Sub-System manual for cartridge preparation procedures.

NOTE: If you are not using a SyQuest approved Host Bus Adapter, the SyQuest Device Driver and associated software utilities may not work properly.

Follow the instructions in the Host Bus Adapter manual you are using for instructions on handling cartridge interchange. If none exists, contact SyQuest or an authorized SyQuest distributor to obtain an approved Host Bus Adapter and Device Driver.

SQ555 – Operation Guide

SECTION 2 SQ555 OPERATION GUIDE

This section gives you general operating instructions for day-to-day use of the SQ555 disk drive and the SQ400 cartridge. It also includes instructions for write-protecting the SQ400 disk cartridge.

2.1 BEFORE YOU BEGIN

The SQ555 is not a diskette drive, nor does it operate exactly like a fixed hard disk drive. When you use the SQ400 disk cartridge, all file directory information is loaded into RAM (System Buffer), not read from the cartridge as is the case with a diskette. In most cases, this System Buffer is not upgraded by DOS when you change your cartridge. Operating system does not know that you changed cartridge. In some cases, your operating system or Host Bus Adapter Driver will make it possible for you to change cartridges.

NOTE: If your Driver software does not support this cartridge change operation, you must reboot your computer when you change the cartridge to ensure that you do not lose data.

2.2 HANDLING INSTRUCTIONS

Here are a few general rules to follow when handling either the SQ555 drive or the SQ400 cartridge:

- Always observe static discharge precautions when handling your SQ555 drive.
- Never leave the cartridge partially inserted in the drive.
- Use only SyQuest-approved cartridges.
- Do not turn off the power to the computer to remove the disk cartridge. If power is turned off, wait at least 30 seconds before removing the disk cartridge. Removing the cartridge before it has stopped spinning may result in damage to the disk recording surface and the read/write heads.
- Always remove the cartridge before you move the drive or the computer.
- Do not apply cleaners or lubricants of any kind to any part of the drive or cartridge.
- To keep the cartridge dust free and to protect it from excessive shock damage, always keep the cartridge in its protective case when not in use.
- Never open the cartridge; this may contaminate the disk surface resulting in severe damage to the cartridge and to the disk drive.
- Allow the cartridge to stabilize at room temperature before you use it in an environment with a temperature different from the one in which it was stored. Setting the cartridge in the environment in which it will be used for approximately an hour (in its protective case, of course) will give the cartridge time to stabilize.

CAUTION

This precaution includes situations such as moving a cartridge from a cold car to warm drive, from a hot car to an air-conditioned environment, or any similar circumstance.

- Do not drop the cartridge; this may damage it, causing head crashes and loss of the disk and stored data.

SQ555 – Operation Guide

- Do not use a bulk tape eraser to erase the cartridge.
- Do not expose the cartridge to magnetic fields.
- Do not apply cartridge labels that will interfere with the operation of the drive, and do not mark on the labels with a graphite pencil. The graphite dust from pencil markings may contaminate the disk surface. Use the label areas provided.
- Avoid performing operations among multiple versions of your DOS operating system. This may cause loss of data.

2.3 OPERATING SYSTEM SOFTWARE

Avoid using the same cartridge with different versions of the operating system. For example, do not use the same cartridge to perform operations for use under DOS 2.1 and DOS 3.3. Performing operations between different versions of an operating system may cause loss of data.

2.4 INSERTING AND REMOVING THE SQ400 DISK CARTRIDGE

Follow these procedures to insert and remove the SQ400 disk cartridge:

2.4.1 Inserting The Cartridge

- a. Hold the SQ400 disk cartridge so that the cartridge head access door is toward the drive and the red write-protect switch is on the bottom.
- b. Insert the cartridge into the drive through the drive door. See FIGURE 2-1. When the cartridge slides into the drive and comes to a stop, the load lever pops out. See FIGURE 2-2.

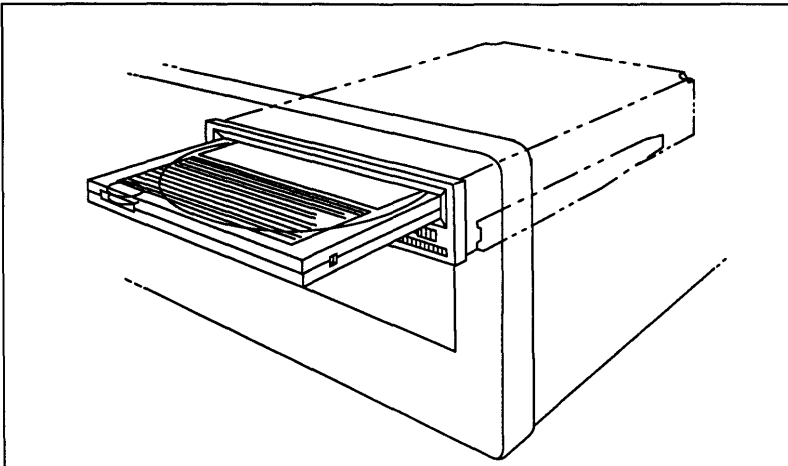

Figure 2-1. Inserting The Cartridge

SQ555 – Operation Guide

- c. Push the load lever to the left until it is flush with the front panel. See FIGURE 2-2. The AMBER/RED LED light starts to flash as the drive begins to spin up the disk.

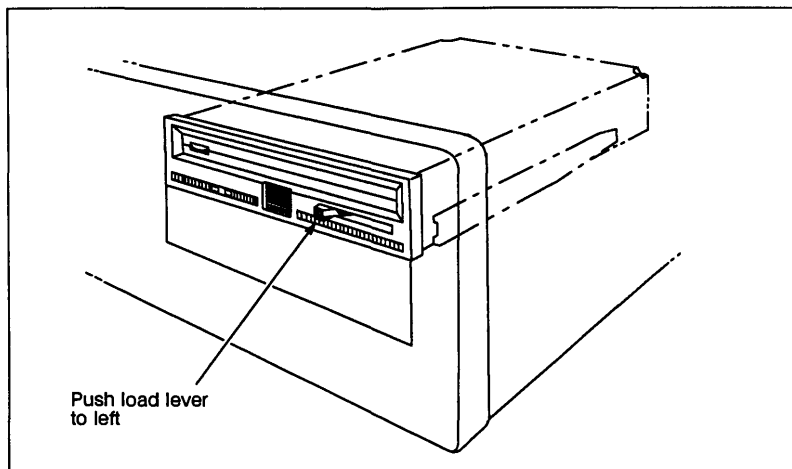

Figure 2-2. Spinning Up The Disk

When the AMBER/RED LED on the front panel is steady, the disk has completely spun up and the head load process is underway. When the AMBER/RED LED goes out and the GREEN LED is steady, the drive is ready. See FIGURE 2-3.

In some cases, your drive may stop during the startup sequence and display a repeating sequence of flashing LEDs. These flashes indicate that an error has occurred. See Table 5-1 in Section 5.1.5 for a list of errors.

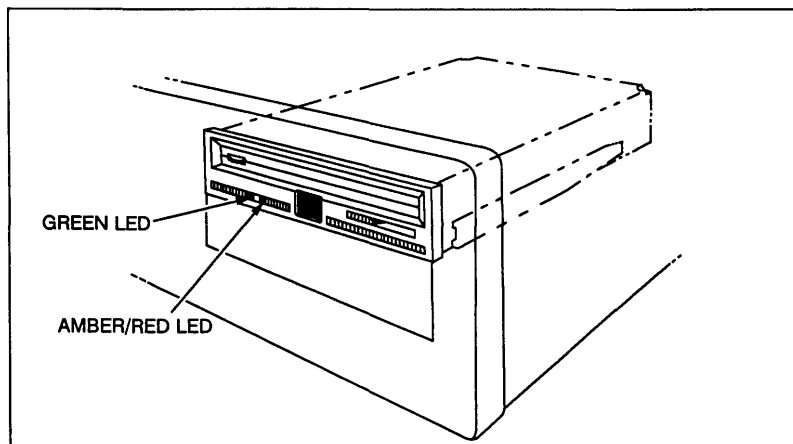

Figure 2-3. The LEDs

SQ555 – Operation Guide

2.4.2 Removing the Cartridge

- a. To remove a cartridge, press the the stop button. See FIGURE 2-4. The cartridge load lever pops out, the AMBER/RED LED begins flashing, and the drive begins spinning down the disk.

CAUTION

Do not proceed until the disk has completely spun down, which is indicated when the AMBER/RED LED on the front panel goes out. This takes about ten seconds.

- b. When the AMBER/RED LED goes out, push the load lever to the right until it is flush with the front panel. The cartridge ejects.

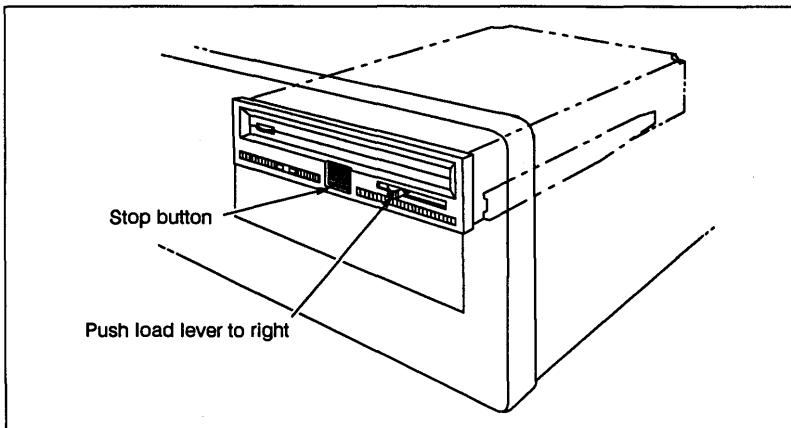

Figure 2-4. Removing The Cartridge

- c. Place the cartridge in its protective case.

CAUTION

It is important that you remove the cartridge before you turn off your computer. If you turn off the computer first, the automatic disk spin-down operation doesn't occur, and the disk will freewheel for up to 30 seconds before it stops spinning. If you attempt to remove the cartridge at this time, you may damage the cartridge and possibly lose data.

2.5 FORMATTING THE CARTRIDGE

Each time you use a NEW SQ400 cartridge, you must prepare the disk for use, similar as you would a new fixed hard disk. In most cases this means partitioning and formatting (or initializing) the disk.

See Section 1.3 - PREPARING A CARTRIDGE FOR USE - for information and detailed instructions and procedures.

SQ555 – Operation Guide

2.6 WRITE-PROTECTING THE SQ400 DISK CARTRIDGE

The SQ400 disk cartridge is equipped with a red write-protect cylinder located on the lower-left side of the plastic case. To write-protect a disk, turn the cartridge over and rotate the circular red cylinder clockwise using a small screwdriver or small coin. A small window on the front of the cartridge (the part facing out from the drive when the cartridge is inserted) indicates whether or not the disk is write-protected. If the window shows red, the disk is write-protected, otherwise it is not write- protected. See FIGURE 2-5.

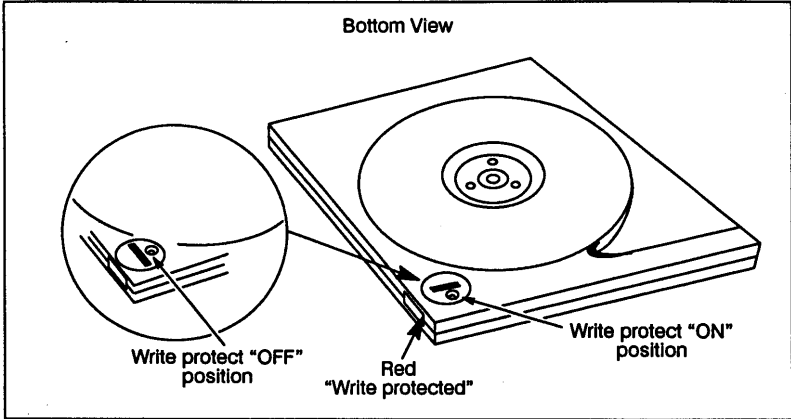

Figure 2-5. Cartridge Write-Protect Cylinder

SQ555 – Functional Characteristics/Overview

SECTION 3

SQ555 FUNCTIONAL CHARACTERISTICS/OVERVIEW

3.1 GENERAL OPERATION

The SQ555 disk drive is a SCSI direct-access block device containing all the electronic and mechanical components necessary to control the drive motor and read/write heads, manage the SCSI bus, execute the SCSI commands, and handle data transfer between the SCSI bus and the disk cartridge.

The primary physical format of the disk cartridge is compatible with any operating system. With proper File System Translator (FST) software, you can transfer data from an SQ555 disk cartridge to different computers and programs. You can also swap cartridges between any number of SQ555 drives, that have been formatted by similar Host Bus Adapters.

CAUTION

Dissimilar Host Bus Adapter Logical format may preclude cartridge interchangeability.

With a cartridge installed, the SQ555 is essentially a 44 MB formatted hard disk. The average access time for the drive is less than 25 milliseconds, and the drive supports ECC and automatic retry. Defect management includes both track and sector sparing and is transparent to the user. The interleave is set to 1:1, and the SQ555 can run at data transfer rates of up to 1.25 MB/s. Figure 3-1 is a simplified block diagram of the SQ555 drive electronics.

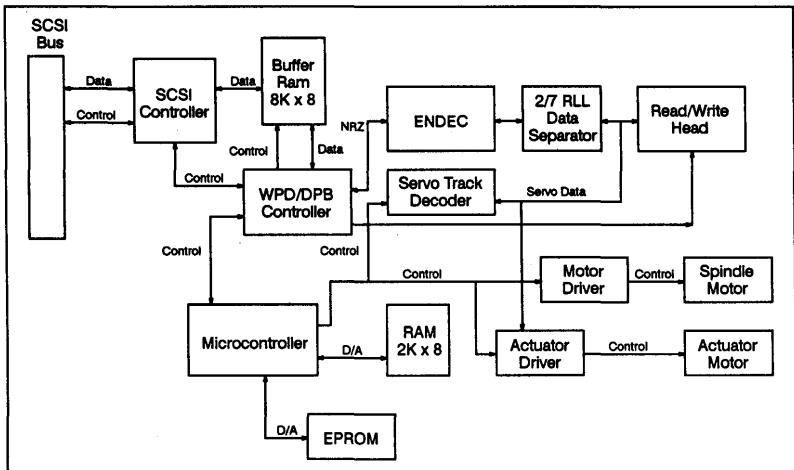

Figure 3-1. Drive Electronics Block Diagram

3.2 FUNCTIONAL OVERVIEW

The SCSI controller receives commands and data sent to the SQ555 from the computer and passes them to the Data Buffer under the control of the disk controller and the Microcontroller. The Microcontroller then stores any necessary parameters in the scratchpad RAM, reads the commands from the buffer, and executes the command.

SQ555 – Functional Characteristics/Overview

The disk controller reads incoming data from the host out of the buffer, converts it into NRZ code, and passes it to the Encoder/Decoder (ENDEC). The ENDEC then converts the NRZ-coded data to 2/7 RLL code and sends it to the read/write head. The Microcontroller positions the read/write head according to the target address passed to it in the command block that precedes the incoming data block.

The read/write heads read the outgoing data from the cartridge. The data is then passed to the ENDEC in 2/7 RLL code. The ENDEC converts the 2/7 RLL-coded data to NRZ-coded data and passes it to the disk controller. The disk controller converts the NRZ data into an 8-bit parallel data stream and writes it into the Buffer RAM. The SCSI controller, under the direction of the disk controller and the Microcontroller, reads the outbound data out of the buffer and onto the SCSI bus.

Use the SyQuest cleaning cartridge (C-CART) kit P/N 58061-001 for cleaning the SQ555 disk drive's spindle motor hub.

3.3 SCSI CONTROLLER

The SCSI controller provides parity generation and/or checking, executes bus arbitration, and performs handshaking and data latching.

3.3.1 Bus Arbitration

SCSI bus arbitration is executed in conjunction with the disk controller. The disk controller waits for Bus Free (no BSY or SEL), then asserts BSY and the drive's assigned SCSI ID to the SCSI controller. The SCSI controller then asserts BSY on the SCSI bus.

3.3.2 Handshaking And Termination

The SCSI controller assists the disk controller with handshaking by latching data prior to transferring the data from the buffer RAM. This speeds the transfer rate by reducing the REQ/ACK timing constraints.

For all data and control lines, 48 mA open-collector outputs provide physical termination for the bus. As required, you can install or remove the external terminating resistor packs.

NOTE: The terminating resistor packs must remain installed in the last drive in the string. The other drives can be unterminated.

3.4 DISK CONTROLLER

The disk controller provides the circuitry for both the programmable storage controller and the dual port buffer controller.

3.4.1 Programmable Storage Controller (PSC)

The disk controller converts the 8-bit parallel SCSI data in the Buffer RAM into NRZ code, controls data transfer direction (inbound or outbound) and type (command or data) between the SCSI controller, the Buffer RAM, and itself, and provides certain control lines for the ENDEC. The PSC performs CRC and ECC generation and correction.

SQ555—Functional Characteristics/Overview

3.4.2 Data Conversion, Direction, And Type

The 8-bit parallel SCSI data read out of the Buffer RAM is serialized, run through a 32-bit ECC generator, and then sent in NRZ format to the ENDEC. The NRZ output includes address marks, gaps, and ID fields.

The serial NRZ format data input to the PSC from the ENDEC is passed through the ECC generator, then converted into an 8-bit parallel data stream and stored in the Buffer RAM.

A pair of control lines connected to the SCSI controller and the SCSI command type control the direction of transfer and the type of information being passed. The I/O line indicates whether the information is inbound (I) or outbound (O). The C/D line indicates whether or not the information is a command or data block.

3.4.3 Track And Sector Formatting

The disk controller contains a sector format sequencer which provides all the basic sequencing functions the SQ555 requires in order to read and write data. The firmware controls the sector format sequencer. This sequencer defines the format used for the disk cartridge through programmable internal registers. See Section 4, "The SQ400 Disk Cartridge" for more information.

3.5 DUAL PORT BUFFER CONTROLLER

The dual port buffer controller manages transfers into and out of the Buffer RAM, resolves priority conflicts over access to the buffer between the PSC and the host, and provides SCSI bus arbitration.

3.5.1 Buffer RAM Management

A 14-bit wide address bus and a pair of control lines to the Buffer RAM are used to control reads and writes to or from the buffer.

3.5.2 Data Management

The buffer controller uses a set of control lines between itself and the SCSI controller to manage data transfers between the SCSI controller and the buffer.

3.5.3 Conflict Resolution And SCSI Bus Arbitration

The buffer controller resolves priority conflicts and allows the PSC to have priority over the host processor whenever a conflict over buffer access occurs. The effect of the priority resolution is that a virtual hold is placed on the host processor until the PSC has completed its buffer access.

The buffer controller supports a two-wire SCSI bus arbitration logic. With either Select In or Busy In asserted by the SCSI controller, the buffer controller recognizes a Bus Busy state on the SCSI Bus. The buffer controller allows the Microcontroller to stack a request to use the SCSI bus. When both Select In and Busy In have been inactive for 100 ns, the buffer controller will assert Busy Out to the SCSI bus, and arbitration for bus use will be executed in the normal manner.

3.6 BUFFER RAM

The Buffer RAM is an 8K Static RAM that operates as a circular FIFO. The 8-bit RAM bus shared by the Buffer RAM, the SCSI controller, and the disk controller reads data out of and writes data into the buffer.

SQ555 – Functional Characteristics/Overview

3.7 MICROCONTROLLER

The Microcontroller manages all the functions of the disk controller and the SCSI controller; controls the drive motor, door solenoid, and actuator motor; executes the SCSI commands the host sends to the SQ555; and performs the self-tests and on-board diagnostics installed in the firmware.

3.8 ENCODER/DECODER

The Encoder/Decoder converts NRZ format data from the disk controller into 2/7 RLL format data for writing to the disk cartridge, and converts the 2/7 RLL format data read off the disk cartridge into NRZ format data for output to the disk controller. It also generates and detects address marks that are used to synchronize the data conversion.

3.9 MECHANICAL COMPONENTS

The read/write heads, actuator, spindle motor, door (and actuator) solenoid, and cartridge load tray compose the mechanical components of the SQ555. A rotary voice coil actuator drives the read/write heads, and the brushless three-phase spindle motor rotates the disk. The Microcontroller energizes the actuator solenoid and loads the read/write heads. When power is off, the actuator solenoid holds the read-write heads from moving. The actuator solenoid, controlled by the Microcontroller, locks the cartridge in place by pinning the cartridge tray. Figure 3-2 shows the SQ555 mechanical components.

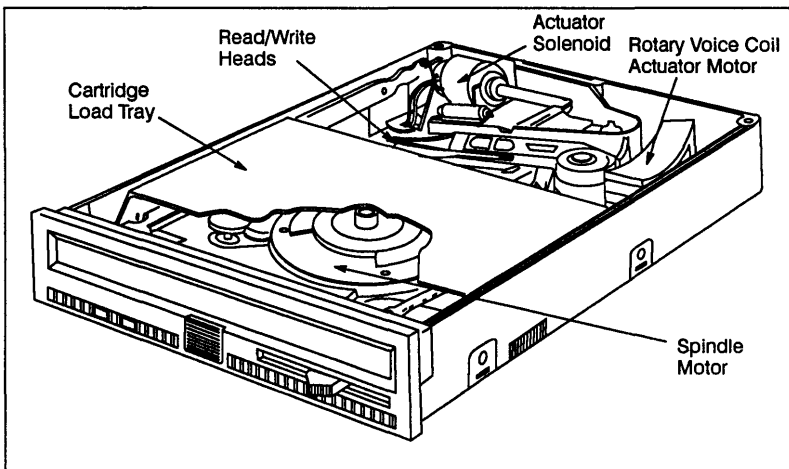

Figure 3-2. Mechanical Components

SQ555 – SQ400 Disk Cartridge

SECTION 4 SQ400 DISK CARTRIDGE

The SQ555 Disk Drive uses the SQ400 removable hard disk cartridge. The SQ400 is a 55 MB (unformatted) or 44 MB (formatted), dual-surface hard medium disk enclosed in a plastic protective housing.

4.1 OVERVIEW

Each disk surface on the SQ400 is divided into 1379 tracks. The first 34 tracks define the outer guard band, and the last 60 tracks define the inner guard band. Each surface contains 1275 data tracks, four alternate tracks, four maintenance tracks, and a diagnostic track.

Each track is divided into 70 zones, two of which are reserved for spares. A servo and 305 bytes of header, data, ECC, and sync patterns are in each zone.

4.2 DISK INFORMATION PATTERNS

4.2.1 Servo Address Patterns

A servo address reading equal to the current track number plus 2048 identifies physical sector 0 (zone 0) of each track. Each servo address word consists of 12 binary di-bits preceded by a binary di-bit synch bit.

4.2.2 Position Patterns

Position patterns consist of two alternating burst patterns laid down twice, recorded after each servo address on all 1379 physical tracks and each surface.

4.2.3 Sector Format

Each formatted sector consists of a header and a data record. A preamble and a synch pattern precede the header and data record. The header record has 2 bytes of CRC appended to it, and is followed by a postamble.

4.3 TRACK ASSIGNMENT

4.3.1 Data Format and Flaw Assignment

The data tracks on the SQ400 run from servo track 0034 to servo tracks 1316 for each surface. The drive reserves servo tracks 256,512,768,1024 on both surfaces for its use. Data track numbers range from 0000 to 1283. Tracks 0000 to 1274 are the primary data tracks, tracks 1275 to 1278 are the alternate tracks, and track 1279 is the system diagnostic track.

Data sector 0 of an even track is defined as the second physical sector. Data sector 0 of an odd track is defined as the 36th physical sector. Thus, the position of data sector 0 is skewed 180 degrees between adjacent tracks. This variance allows for sufficient time to seek to the next track during multiple-track read or write operations.

4.3.2 System Tracks

These tracks contain drive parameter and media flaw information.

SQ555 – Diagnostics

SECTION 5 SQ555 DIAGNOSTICS

The SQ555 firmware resides in the ROM mounted on the main logic board. The firmware contains all the routines necessary to execute supported SCSI commands, run the Microcontroller, and perform self-test diagnostics. The SCSI commands are briefly described in Section 6. The self-test routines are described in this chapter.

5.1 OVERVIEW

The SQ555 has two types of self-test routines: power-up and diagnostic. It always executes the power-up tests prior to normal operation. It can execute the diagnostic tests off line with special jumper blocks attached to the rear of the drive. These tests supersede normal operation. The actual tests run depend upon the position of the test jumpers. The following section describes each test.

5.1.1 Power-Up Test

When power is applied to the drive main logic board, the start-up routines in the SQ555 ROM execute a series of tests on the drive's electronic components to establish the readiness of the drive. The first test is a checksum operation on the SQ555 ROM. If this test passes, a series of reads and writes test the Microcontroller's registers, internal RAM, and scratch pad RAM. When the Microcontroller has passed the power-up tests, a series of reads and writes test the controller, and a read/write test is run on the buffer RAM. When the buffer RAM passes, the power-up tests are complete and the firmware proceeds to the diagnostic tests if selected by the test jumper position.

5.1.2 Performance Diagnostic Tests

There are five different DRIVE PERFORMANCE diagnostic tests that the SQ555 can execute. The tests are numbered 0-3 and 6. You select the tests by putting a jumper on the "T" selection pins and another jumper across the unit select jumper pins "A", "B", or "C", depending on the setting for drive ID corresponding to the test desired. See FIGURE 1.2.

These jumpers must be set prior to powering up the drive. See Section 5.1.3 for jumper settings and test run procedure.

A description of each test follows. All tests cycle continuously, stopping and starting the spindle once each cycle.

A. TEST 0

Test 0 is a seek-read test of the entire media. The test consists of a sequence of 256 random seeks, followed by two incremental reads of the entire disk surface, repeated six times.

B. TEST 1

Test 1 is a random seek-read media test. The test consists of a sequence of 256 seeks followed by 35 random reads, repeated twice.

C. TEST 2

Test 2 is a seek test of the media. The test consists of 25,600 random seeks, repeated once. Any errors encountered will cause the test to terminate early. Blinking front panel LED's indicate the failure type. See Table 5-1.

SQ555 – Diagnostics

D. TEST 3

Test 3 is the same as Test 2, except that any errors encountered do not cause the test to terminate.

E. TEST 6

Test 6 is a write-read test of track 1279. The test consists of a seek to the diagnostic track, followed by an incremental write-read operation by sector, until all sectors for the track have been tested, repeated once.

F. TEST 7

WARNING

Reserved for SyQuest usage. Customers should not attempt to use this function. If this function is used, the users stored data will be destroyed.

5.1.3 The Procedure To Install The Diagnostic Test Jumpers And To Perform The Self Test Routine, Is As Follows:

STEP 1. REMOVE ALL POWER TO THE DRIVE (TURN OFF DRIVE POWER)

STEP 2. INSERT A JUMPER ON PINS "T" OF THE UNIT SELECT JUMPER, BLOCK. (See FIGURE 1.2 in Section 1 for pin assignments)

STEP 3. INSTALL JUMPERS AS REQUIRED ON THE UNIT SELECT JUMPER BLOCK TO SELECT THE DIAGNOSTIC TEST OF YOUR CHOICE. (See FIGURE 1.2 in Section 1 for pin assignments)

TO RUN TEST 0	NO OTHER JUMPERS
TO RUN TEST 1	INSERT JUMPER ON PINS "A"
TO RUN TEST 2	INSERT JUMPER ON PINS "B"
TO RUN TEST 3	INSERT JUMPER ON PINS "A & B"
TO RUN TEST 6	INSERT JUMPER ON PINS "B,&C"

STEP 4. TO START TEST - TURN ON POWER TO DRIVE

5.1.4 Requirements For Diagnostic Tests To Run Properly

- A. TEST WILL NOT RUN PROPERLY IF THE POWER IS NOT OFF AT THE BEGINNING OF THE TEST.
- B. ACCIDENTAL SYSTEM OR DRIVE POWER INTERRUPTION WILL APPEAR AS A DRIVE FAILURE. RESTART TEST IF THIS SHOULD OCCUR.
- C. REMOVAL OF THE CARTRIDGE WILL CAUSE THE TEST TO TERMINATE. REINSTALL THE CARTRIDGE, TURN POWER OFF, WAIT 10 SECONDS, TURN POWER BACK ON TO RESTART TEST. OFF, WAIT 10 SECONDS, TURN POWER BACK ON TO RESTART TEST.

SQ555 – Diagnostics

5.1.5 Power Up & Performance Diagnostic Test Error Reporting

The SQ555 has a unique design feature that provides failure diagnostic information through the use of the drive front panel LEDs. See FIGURE 2.3 on page 2-3.

The AMBER/RED and GREEN front panel LEDs report errors encountered during the power-up and diagnostic tests. These LEDs are flashed a variable number of times, depending upon the error encountered during the power up sequence test or during the diagnostic testing. The error code displayed by the LEDs cycles continuously, with the GREEN LED flashing a number of times first, followed by the AMBER/RED LED.

Table 5-1. shows the correspondence between the error encountered and the number of LED flashes.

Table 5-1. LED Error Reporting Table*

Number of LED Blinks		Error Description
GREEN	AMBER/RED	
0	1	Too many files created/wrong cartridge used
0	2	Maintenance track read error
0	3	Maintenance track write error
0	4	Drive not ready
0	5	No spare maintenance sectors
0	6	Cartridge write protected
0	7	Self test FAT/FED sector full
1	1	EPROM failed checksum test
1	2	Microcontroller internal RAM failure
1	3	Scratchpad RAM failed
1	4	Self test seek error
1	5	Seek error
1	6	Read Error
1	7	Write Error
2	1	Disk controller (SERDES) failed
2	2	SERDES Sequencer RAM test 1 failed
2	3	SERDES Sequencer RAM test 2 failed
2	4	R/W buffer RAM address register failed test 1
2	5	R/W buffer RAM address register failed test 2
2	6	R/W buffer RAM failed test 1
2	7	R/W buffer RAM failed test 2
3	1	R/W buffer RAM port 0 failed
3	2	Amber/Red/Green LEDs port failure
3	3	R/W buffer RAM port 2 failed
3	4	Self test write error (scan process)
3	5	Invalid self test number
4	1	Spindle motor failed to start
4	2	Spindle motor fails to spin up to speed
4	3	Spindle motor spins too fast
5	1	Power supply failure (voltages out of spec)
5	2	Spindle motor speed abnormal < > .5% or no servos
5	3	No servos detected after spin up
5	4	No servos found head 0 (bad head)
5	5	No servos found head 1 (bad head)
6	1	ADC calibration failure
6	2	ADC high current failure
6	3	ADC low current failure
off	flashing	Failed power-up sequence; possible defective cartridge; heads not loaded; possible defective drive

*If any of these errors occur, check that you are following the procedure correctly. If the error still occurs, contact your distributor for technical support.

SQ555 – SCSI Implementation

SECTION 6 SCSI IMPLEMENTATION

The SyQuest SQ555 complies fully with the SCSI standard as defined in the SCSI American National Standard for Information Systems X3.131-1986 (hereafter referred to as X3.131).

6.1 OVERVIEW

SCSI is an 8-bit parallel data bus supported by a machine-independent message and command protocol. This independence allows SCSI devices to be connected regardless of the manufacturer.

A maximum of eight devices can connect to a SCSI bus. Only two devices may use the bus at any one time, one initiator and one target. An initiator device sends commands to other devices: a computer is an example of an initiator device. A target device executes commands sent from other devices: the SQ555 is an example of a target device.

Each device on the bus contains a SCSI controller that provides all the bus management functions necessary to arbitrate and select the bus and handle the SCSI protocol.

Commands sent from an initiator (usually the host computer) access and control peripheral devices. X3.131 defines a specific library of SCSI commands. The standard also permits manufacturers to create a number of vendor-specific commands. The actual execution of the command depends on the code in the target device firmware. The result of a command given by two different devices will be the same if the devices are of the same type (for example, two hard disk drives from different manufacturers); that is, devices of the same type may accomplish their work differently, but what they return to the initiator must be the same.

The exchange of messages, commands, and transfer data across the SCSI bus occurs during one of the bus phases. There are eight phases in SCSI. Specific activities take place during each phase, and any software that controls SCSI devices (for example a device driver) must be able to determine which phase is currently executing on the bus.

The devices resident on the SCSI bus connect in a daisy-chain configuration. X3.131 also provides the standard for the connecting cables. Table 6-1 provides concise definitions for the SCSI bus signal lines.

SQ555 – SCSI Implementation

Table 6-1. SCSI Signal Lines

NAME	USE
BSY	An OR-tied line that indicates that the bus is in use by a device.
SEL	The line that the initiator uses to select a target device and that the target uses to reselect an initiator.
C/D	The line, driven by the target, that indicates whether control or data information is on the bus.
I/O	The line, driven by the target, that indicates direction of data transfer with respect to the target.
MSG	The line, driven by the target, that indicates a message is being transferred.
REQ	The line that the target uses to set the Request portion of the bus handshake.
ACK	The line that the initiator uses to set the Acknowledge portion of the bus handshake.
ATN	The line that the initiator uses to set the Attention condition.
RST	An OR-tied line that indicates that the Reset condition has been set.
DB7-DB0	The 8-bit parallel data bus. DB7 has the highest priority during arbitration.
P	The parity bit which is part of the data bus. Parity is odd. It is not valid during arbitration.

SQ555 – SCSI Implementation

6.2 SCSI COMMAND SET

The SQ555 SCSI command set contains 26 commands. Of these commands, one is specific to the SyQuest SQ555 and is described in detail. X3.131 defines the remaining SCSI commands supported by the SQ555. Use the following brief descriptions of the X3.131-standard commands as a quick reference rather than a detailed programming aid. For more information on these commands, see the SCSI American National Standard for Information Systems (X3.131). Table 6-2 lists the full set of SCSI commands.

Table 6-2. SQ555 ANSI Commands Description

OpCode	Type	Description
00H	B	Test Unit Ready
01H	B	ReZero Unit
03H	B	Request Send
05H	B	Format Unit
07H	B	Reassign Blocks
08H	B	Read
0AH	B	Write
0BH	B	Seek
11H	B	Read Usage Counters
12H	B	Inquiry
15H	B	Mode Select
16H	B	Reserve
17H	B	Release
1AH	B	Mode Sense
1CH	B	Receive Diagnostic Results
1DH	B	Send Diagnostic
1EH	B	Prevent/Allow Medium Removal
25H	E	Read Capacity
28H	E	Extended Read
2AH	E	Extended Write
2BH	E	Extended Seek
2FH	E	Verify
37H	E	Read Defect Data
3BH	E	Write Buffer
3CH	E	Read Buffer

B = SyQuest Basic Command Set
E = SyQuest Extended Command Set

SQ555 – SCSI Implementation

6.2.1 Test Unit Ready Command Operation Code: 00H

Table 6-2-1. Test Unit Ready Command

BIT BYTE	7	6	5	4	3	2	1	0
0	Operation Code							
1	Logical Unit Number			Reserved				
2	Reserved							
3	Reserved							
4	Reserved							
5	Reserved					Flag	Link	

The Test Unit Ready Command provides a means to check if the drive is ready. This is not a request for a self-test. If the drive is ready, the command is terminated with Good Status, and the sense key is set to No Sense.

6.2.2 Rezero Unit Command Operation Code: 01H

Table 6-2-2. Rezero Unit Command

BIT BYTE	7	6	5	4	3	2	1	0
0	Operation Code							
1	Logical Unit Number			Reserved				
2	Reserved							
3	Reserved							
4	Reserved							
5	Reserved					Flag	Link	

The Rezero Unit Command requests that the Target move the heads to Track 0.

SQ555 – SCSI Implementation

6.2.3 Request Sense Command Operation Code: 03H

Table 6-2-3. Request Sense Command

BIT BYTE	7	6	5	4	3	2	1	0
0	Operation Code							
1	Logical Unit Number			Reserved				
2	Reserved							
3	Reserved							
4	Allocation Length							
5	Reserved						Flag	Link

The Request Sense Command requests that the Target transfer Sense data to the Initiator. Extended Sense is supported and will be provided if the Allocation Length is set to 5 or greater. When the Allocation Length is set to a value of 0-4 bytes, then Nonextended Sense will be generated.

The Sense data is valid for a Check Condition Status returned on the prior command. This sense data is preserved for the Initiator until retrieved by the Request Sense command, or until receipt of the next command from the Initiator. Sense shall be cleared upon receipt of any subsequent command to the drive from the Initiator receiving the Check Condition Status.

Allocation Length: Specifies the number of bytes that the Initiator has allocated for returned sense data. An Allocation Length of zero indicates that four bytes of Sense data will be transferred. Any other value indicates the number of bytes to be transferred. The SQ555 will terminate the data in phase when the Allocation Length bytes have been transferred or when all available Sense data has been transferred to the Initiator.

A Check Condition Status is used only to report fatal errors for this command. For example:

- The SQ555 receives a nonzero reserved bit in the Command Descriptor Block.
- An unrecovered parity error occurs on the data bus.

Following a fatal error on a Request Sense Command, sense data may be invalid. Refer to Section 6.3 for Sense Keys and Error Codes.

SQ555 – SCSI Implementation

6.2.3.1 Non-Extended Sense

Table 6-2-3-1. Non-Extended Sense Data Format

BIT BYTE	7	6	5	4	3	2	1	0
0	Valid	Error Class			Sense Key			
1	Logical Block Address (MSB)							
2	Logical Block Address							
3	Logical Block Address (LSB)							

Non-extended Sense is provided for compatibility with systems that do not accept Extended Sense.

VALID: Indicates that the information bytes specify the unsigned Logical BLock Address associated with sense key. Sense keys are described in section 6.3

Error Class: Error class specifies a class of errors from zero (0) through six (6) are used in nonextended sense only.

Sense Key: See section 6.3.

Logical Block Address: This field point to the sector associated with the specific error.

SQ555—SCSI Implementation

6.2.3.2 Extended Sense

Error class seven (7) specifies extended sense. Sense key zero (0) specifies the Extended Sense data format. Error codes 1H through 0FH are reserved.

Table 6-2-3-2. Extended Sense Data Format

BIT BYTE	7	6	5	4	3	2	1	0
0	Valid	Error Class (7)			Sense Key (0)			
1	Reserved							
2	Reserved				Sense Key			
3	Logical Block Address (MSB)							
4	Logical Block Address							
5	Logical Block Address							
6	Logical Block Address (LSB)							
7	Additional Sense Length							

VALID: Indicates that the information bytes specify the unsigned Logical Block Address associated with the sense key. Sense keys are described in Section 6.3.

Sense Key: See section 6.3.

Logical Block Address: This field points to the sector associated with the specific error.

Additional Sense Length: This field indicates the number of additional sense bytes associated with this error.

SQ555 – SCSI Implementation

Additional Sense Bytes

BIT BYTE	7	6	5	4	3	2	1	0
8	Reserved							
9	Reserved							
10	Reserved							
11	Reserved							
12	Additional Sense Code							
13	Reserved							
14	Reserved							
15	Reserved							
16	Reserved							
17	Reserved							
18	Cylinder (MSB)							
19	Cylinder (LSB)							
20	Head							
21	Sector							

Additional Sense Code: See tables 6-3-2.

Cylinder/Head/Sector: Specifies the disk physical cylinder, head, and sector associated with an error.

On overflow of usage counter error, the additional bytes will contain the alternate error code and the nine usage counter bytes as follows:

SQ555 -- SCSI Implementation

Additional Sense Bytes for Usage Counters

BIT BYTE	7	6	5	4	3	2	1	0
18	Block Read (MSB)							
19	Block Read							
20	Block Read (LSB)							
21	Seeks (MSB)							
22	Seeks							
23	Seeks (LSB)							
24	Uncorrectable Read Errors							
25	Correctable Read Errors							
26	Seek Errors							

Block Read: Specifies the number of sectors that have been read since power on, or the last read usage counter command, or the last presentation of this field as sense bytes.

Seek: Specifies the number of times the read/write heads were repositioned to another cylinder.

Uncorrectable Read Error: Specifies the number of uncorrectable read errors.

Correctable Read Error: Specifies the number of times that ECC correction were required to recover data.

Seek Errors: Specifies the number of times that seek retries were required to recover data.

SQ555 – SCSI Implementation

6.2.4 Format Unit Command Operation Code: 04H

Table 6-2-4. Format Unit Command

BIT BYTE	7	6	5	4	3	2	1	0
0	Operation Code							
1	Logical Unit Number			FMTDATA	C MPLST	Defect List Format		
2	Format Data							
3	Interleave (MSB)							
4	Interleave (LSB)							
5	DTAVLD	INHIBIT DATASCAN	Reserved			Flag		Link

The Format Command will write all data fields with the format specified by a previous Mode Select Command. If no Mode Select Command has been executed, the previous format will be used. The factory default format is 512-byte logical blocks and a 1:1 interleave. The SQ555 does not change the physical sector size of 256 bytes per sector. Only the data fields of the sectors are formatted, the sector servos and headers are never rewritten.

The SQ555 provides a manufacturer's defect list written on the drive that is used during the format operation to bypass defects which were identified during the manufacturing process. The manufacturer's list may not be modified by the user. Additional defects may be added to the user's defect list. These defects are supplied as data to the Format Command and usually consist of logical or physical blocks.

Defects consisting of full tracks may only be specified using the physical defect list format. Refer to table 6-2-4-3.

Four format modes are supported by the SQ555:

1. Format with known defect list (original manufacturer's defect list plus any previously supplied additions).
2. Format with known defect list plus supplied defects in Logical Block Format.
3. Format with known defect list plus supplied defect in Physical Address Format.
4. Format with original manufacturer's defect list only (remove any previously supplied additions).

Format Data (FMTDATA): If one, indicates that format data is supplied during the data-out phase. The defect list included with this data specifies the defects which are to be entered into the defect map. The format of the defect list is determined by the three bit defect list format field. The FMTDATA bit, if zero, indicates that the data-out phase will not occur and no defect data will be supplied by the initiator. Additional defects will be added if found by the drive.

Complete List (C MPLST): If one, indicates the data supplied is the complete list of known defects in addition to the manufacturer's defect list. Any previous initiator specified defect map or defect data shall be erased. Additional defects will be added by the drive if the Verify option is selected. A C MPLST bit of zero indicates

SQ555 – SCSI Implementation

that the data supplied is in addition to existing defect data using the current format. When using the block format, the defect list refers to the current block length (and not to the new block length, if it is different) and the defect list refers to current logical block addresses (not physical addresses). Additional defects will be added if found by the drive if the Verify option is selected.

Defect List Format: See table 6-2-4-1 for descriptions.

Format Data: Specifies the format data pattern will be used if DTAVLD bit set.

Interleave: requests that the logical blocks be related in a specific fashion to the physical blocks to facilitate speed matching. An interleave value of zero requests that the target use its default interleave (1:1). An interleave value of one requests that consecutive logical blocks be placed in physical consecutive order.

All valid interleave values, including 1:1 are supported by this product. Valid interleave values are from 0 to 67.

Data Valid (DTAVLD): If one (1), then the drive will be formatted using a data pattern from the Format Data byte. If zero (0), then a default data pattern will be used.

Inhibit Data Scan: If one (1), then only the drive parameter tables and defect list tables will be written. No write or read of the data sectors will take place. This bit is provided to allow rapid specification and format handling of defects without the delay of a full media scan.

Table 6-2-4-1. Format Unit Command Variations

BIT REFERENCES					Comments
4	3	2	1	0	
FmtData	CmpLst	Defect	List	Format	
0	X	X	X	X	Format with no defect data sent from the initiator to the target. Add drive detected defects
1	0	0	X	X	Format adding the logical defects specified in the defect list to the known defects. (See table 6-2-4-2.)
1	1	0	X	X	Format using the manufacturing defect list as the full set of known defects. (See table 6-2-4-3.)
1	0	1	0	1	Format adding the physical defects in the defect list to the known defects. (See table 6-2-4-4.)
X = 1 or 0 (i.e., don't care term).					

The defects lists shown in tables 6-2-4-2 and 6-2-4-3 contain a four-byte header followed by one or more defect descriptors. The length of the defect descriptors varies with the format of the defect list.

SQ555 – SCSI Implementation

Table 6-2-4-2. Defect List - Block Format

Defect List Header

BIT BYTE	7	6	5	4	3	2	1	0
0	Reserved							
1	FOV	0	DCRT	STPF	Reserved			
2	Defect List Length (MSB)							
3	Defect List Length (LSB)							

Format Option Valid (FOV): If one (1), enables the DCRT and STPF bits. If zero (0), the drive will use its default settings, (verify and stop on error).

Disable Media Certification (DCRT): Bit of one along with an FOV bit of one disables drive self certification during format. Any defects found will be added to the current defect map.

Stop Format On Error (STPF): Bit of one along with an FOV bit of one tells the drive to abort with an error if it cannot read the user defect list. If the drive aborts it will return CHECK CONDITION with a sense key of MEDIUM ERROR.

Defect List Length: In each table specifies the total length in bytes of the defect descriptors that follow. In table 6-2-4-2, the defect list length is equal to four times the number of defect descriptors. In table 6-2-4-3, the defect list length is equal to eight times the number of defect descriptors.

The total number of defects and reassigned blocks can not exceed 100.

Defect Descriptor(s)

BIT BYTE	7	6	5	4	3	2	1	0
0	Defect Block Address (MSB)							
1	Defect Block Address							
2	Defect Block Address							
3	Defect Block Address (LSB)							

Each defect descriptor for the block format specifies a four-byte defect block address that contains the defect.

SQ555 – SCSI Implementation

Table 6-2-4-3. Defect List - Block Format When Using Manufacturing Defect List

Defect List Header

BIT BYTE	7	6	5	4	3	2	1	0
0	Reserved							
1	FOV	0	DCRT	STPF	Reserved			
2	0							
3	0							

Format Option Valid (FOV): If one (1), enables the DCRT and STPF bits. If zero (0), the drive will use its default settings, (verify and stop on error).

Disable Media Certification (DCRT): Bit of one along with an FOV bit of one disables drive self certification during format. Any defects found will be added to the current defect map.

Stop Format On Error (STPF): Bit of one along with an FOV bit of one tells the drive to abort with an error if it cannot read the user defect list. If the drive aborts it will return CHECK CONDITION with a sense key of MEDIUM ERROR.

The total number of defects and reassigned blocks can not exceed 100.

SQ555 – SCSI Implementation

Table 6-2-4-4. Defect List – Physical Sector Format

Defect List Header

BIT BYTE	7	6	5	4	3	2	1	0
0	Reserved							
1	FOV	0	DCRT	STPF	Reserved			
2	Defect List Length (MSB)							
3	Defect List Length (LSB)							

Format Option Valid (FOV): If one (1), enables the DCRT and STPF bits. If zero (0), the drive will use its default settings, (verify and stop on error).

Disable Media Certification (DCRT): Bit of one along with an FOV bit of one disables drive self certification during format. Any defects found will be added to the current defect map.

Stop Format On Error (STPF): Bit of one along with an FOV bit of one tells the drive to abort with an error if it cannot read the user defect list. If the drive aborts it will return CHECK CONDITION with a sense key of MEDIUM ERROR.

Defect List Length: In each table specifies the total length in bytes of the defect descriptors that follow. In Table 6-2-4-2, the defect list length is equal to four times the number of defect descriptors. In Table 6-2-4-3, the defect list length is equal to eight times the number of defect descriptors.

The total number of defects and reassigned blocks can not exceed 100.

Defect Descriptors

BIT BYTE	7	6	5	4	3	2	1	0
0	Cylinder Number of Defects (MSB)							
1	Cylinder Number of Defects							
2	Cylinder Number of Defects (LSB)							
3	Head Number of Defect							
4	Defect Sector Number (MSB)							
5	Defect Sector Number							
6	Defect Sector Number							
7	Defect Sector Number (LSB)							

Each defect descriptor for the physical sector format specifies a sector-size defect location comprised of the cylinder number of the defect, the head number of defect, and the defect sector number. For determining ascending order, the cylinder number of defect is considered the most significant part of the address and the defect sector number is considered the least significant part of the address.

SQ555 – SCSI Implementation

A defect sector number of 0xFFFFFFFFh indicates that the entire track shall be reassigned.

The total number of reassigned tracks cannot exceed eight. If there are more than four (4) defects in the track, the entire track will be reassigned.

6.2.5 Reassign Blocks Command Operation Code: 07H

Table 6-2-5. Reassign Blocks Command

BIT BYTE	7	6	5	4	3	2	1	0
0	Operation Code							
1	Logical Unit Number			Reserved				
2	Reserved							
3	Reserved							
4	Reserved							
5	Reserved						Flag	Link

This command requests that the Target reassign the defective Logical Blocks to an area on the drive reserved for this purpose.

Blocks that have been reassigned by this command will be added to the "Known Defect List".

The Initiator transfers a defect list that contains the Logical Block Addresses to be reassigned. The Target will reassign the physical medium used for each Logical Block address in the list. The data contained in the logical blocks specified in the defect list will be lost.

If the drive has insufficient capacity to reassign all of the defective logical blocks, the command will terminate with a CHECK CONDITION status and the sense key shall be set to Medium Error. The logical block address of the last Logical Block reassigned will be returned in the information bytes of the Sense data. A maximum of 18 blocks may be reassigned at any time.

The Reassign Blocks defect list contains a four-byte header followed by one or more defect descriptors. The length of each Defect Descriptor is four bytes.

SQ555 – SCSI Implementation

Table 6-2-5-1. Reassign Blocks Defect List

Defect List Header

BIT BYTE	7	6	5	4	3	2	1	0
0	Reserved							
1	Reserved							
2	Defect List Length (MSB)							
3	Defect List Length (LSB)							

The Defect List length specifies the total length in bytes of the Defect Descriptors that follow. The Defect List length is equal to four times the number of Defect Descriptors.

Defect Descriptors

BIT BYTE	7	6	5	4	3	2	1	0
0	Defect Logical Block Address (MSB)							
1	Defect Logical Block Address							
2	Defect Logical Block Block Address							
3	Defect Logical Block Block Address (LSB)							

The Defect Descriptor specifies a four-byte Logical Block Address that contains the defect.

SQ555 – SCSI Implementation

6.2.6 Read Command Operation Code: 08H

Table 6-2-6. Read Command

BIT BYTE	7	6	5	4	3	2	1	0
0	Operation Code							
1	Logical Unit Number			Logical Block Address (MSB)				
2	Logical Block Address							
3	Logical Block Address (LSB)							
4	Transfer Length							
5	INHDMA	LONG	Reserved				Flag	Link

The Read Command Requests that the target transfer data to the Initiator.

Logical Block Address: Specifies the logical block number where the Read operation shall begin.

Transfer Length: Specifies the number of contiguous logical blocks of data to be transferred. A Transfer Length of zero indicates 256 logical blocks shall be transferred. Any other value indicates the number of blocks to be transferred.

Inhibit DMA (INHDMA): If enabled, specifies that the read operation will be performed but the data will not be sent to the Initiator. The data will be left in the drives R/W buffer.

LONG: If enabled, specifies that the six ECC bytes will be read as part of the data field (262 bytes). ECC error detection will be disabled. Only a single sector may be read in this mode.

SQ555 – SCSI Implementation

6.2.7 Write Command Operation Code: 0AH

Table 6-2-7. Write Command

BIT BYTE	7	6	5	4	3	2	1	0
0	Operation Code							
1	Logical Unit Number			Logical Block Address (MSB)				
2	Logical Block Address							
3	Logical Block Address (LSB)							
4	Transfer Length							
5	INHDMA	LONG	Reserved				Flag	Link

The Write Command requests that the Target write the data transferred by the Initiator to the medium.

Logical Block Address: Specifies the logical block number where the write operation shall begin.

Transfer Length: Specifies the number of contiguous logical blocks of data to be transferred. A Transfer Length of zero indicates 256 logical blocks shall be transferred. Any other value indicates the number of logical blocks that shall be transferred.

Inhibit DMA (INHDMA): If enabled, specifies that the write operation will be performed but the data will not be sent to the Initiator. The data will be left in the drives R/W buffer.

LONG: If enabled, specifies that the six ECC bytes will be written as part of the data field (262 bytes). ECC error detection will be disabled. Only a single sector may be written in this mode.

6.2.8 Seek Command Operation Code: 0BH

Table 6-2-8. Seek Command

BIT BYTE	7	6	5	4	3	2	1	0
0	Operation Code							
1	Logical Unit Number			Logical Block Address (MSB)				
2	Logical Block Address							
3	Logical Block Address (LSB)							
4	Reserved							
5	Reserved					Flag	Link	

This command requests that the Target seek to the specified Logical Block Address.

SQ555 – SCSI Implementation

6.2.9 Read Usage Counters Command Operation Code: 11H

Table 6-2-9. Read Usage Counters Command

BIT BYTE	7	6	5	4	3	2	1	0
0	Operation Code							
1	Logical Unit Number			Reserved				
2	Reserved							
3	Reserved							
4	Reserved							
5	Reserved						Flag	Link

The Read Usage Counters Command is provided for tracking the number of blocks read, the number of seeks requiring head motion, the number of correctable/uncorrectable read errors and the number of seek errors. Execution of this command will set the usage counters to zero.

CAUTION

The counter information is stored in RAM and may be lost when power is removed.

When the usage or error counters overflow, an error will be generated on the next command, indicating to the host that this has occurred and the counters will be contained in the Sense information. After the sense information has been retrieved, the usage counters will be reset.

The Mode Select Command is used to enable or disable the counter overflow error; the default is set so error generation is disabled (see Mode Select).

SQ555 – SCSI Implementation

Table 6-2-9-1. Usage Counter Format

BIT BYTE	7	6	5	4	3	2	1	0
0	Blocks Read (MSB)							
1	Blocks Read							
2	Blocks Read (LSB)							
3	Seeks (MSB)							
4	Seeks							
5	Seeks (LSB)							
6	Uncorrectable Read Errors							
7	Correctable Read Errors							
8	Seek Errors							

Blocks Read: Specifies the number of sectors that have been read since power on, or the last read usage counter command, or the last presentation of this field as sense bytes.

Seeks: Specifies the number of times the read/write heads were repositioned to another cylinders.

Uncorrectable Read Errors: Specifies the number of uncorrectable read errors.

Correctable Read Errors: Specifies the number of times that retries were required to recover data.

Seek Errors: Specifies the number of times that seek retries were required to recover data.

SQ555 – SCSI Implementation

6.2.10 Inquiry Command Operation Code: 12H

Table 6-2-10. Inquiry Command

BIT BYTE	7	6	5	4	3	2	1	0
0	Operation Code							
1	Logical Unit Number			Reserved				
2	Reserved							
3	Reserved							
4	Allocation Length							
5	Reserved					Flag		Link

The Inquiry Command requests that information regarding parameters of the Target be sent to the Initiator.

Allocation Length: Specifies the number of bytes that the Initiator has allocated for Sense data. An Allocation Length of zero indicates that no inquiry data will be transferred. This is not considered an error condition. Any other value will indicate the maximum number of bytes to be transferred. The Target will terminate the data-in phase when Allocation Length bytes have been transferred or, when all available Inquiry data has been transferred to the Initiator. The Check Condition status is reported when the Target cannot return the Inquiry data.

The Inquiry data contains a five-byte header, followed by additional parameters, if any.

SQ555 – SCSI Implementation

Table 6-2-10-1. Inquiry Data

Inquiry Header

BIT BYTE	7	6	5	4	3	2	1	0
0	Device Type Code (00)							
1	RMB(1)	Device Type Qualifier (00)						
2	Revision Level (01)							
3	Response Data Format (01)							
4	Additional Length (33H)							
5	Reserved							
6	Reserved							
7	Reserved							
8-15	SYQUEST (ASCII)							
16-31	SQ555 (ASCII)							
32	Hardware Revision Level (ASCII)							
33	Firmware Revision Level (ASCII)							
34	ROM Revision Level (ASCII)							
35	20H							
36	Number of Extents (MSB)						(00H)	
37	Number of Extents (LSB)						(08H)	
38	Group 0 Commands						(00H)	
39	Commands (0-7)						(D9H)	
40	Commands (8-F)						(B0H)	
41	Commands (10-17)						(67H)	
42	Commands (18-1F)						(3EH)	
43	Group 1 Commands						(01H)	
44	Commands (20-27)						(ECH)	
45	Commands (28-2F)						(B1H)	
46	Commands (30-37)						(01H)	
47	Commands (38-3F)						(18H)	
48	End of List						(FFH)	
49	Cartridge Serial Number (MSB)							
50	Cartridge Serial Number							
51	Cartridge Serial Number							
52	Cartridge Serial Number							
53	Cartridge Serial Number							
54	Cartridge Serial Number							
55	Cartridge Serial Number (LSB)							

SQ555 – SCSI Implementation

Removable Medium Bit (RMB): Is set to one, indicating the medium is a removable device.

Device Type Qualifier: Is a seven bit user specified code. This code may be set using the mode select command. The default value is 0.

Revision Level: Is the implemented revision level of this standard and is defined as follows:

00H	Revision level is updated.
01H	First release. This should be used for disk drives that claim to comply with the ANSI standard.
02H -> 0FH	Reserved

The revision level is 1 since this drive conforms to X3.131 ANSI SCSI 1986 specifications.

Additional Length: Specified the length in bytes of additional drive parameters.

A response data format of one indicates conformance to the common command set.

SYQUEST: Contains the letters that make up the word "SYQUEST" in ASCII format.

SQ555: Contains the SyQuest's drive model designation in the ASCII format.

Hardware Revision Level: Contains the drive hardware revision level.

Firmware Revision Level: Contains the drive firmware revision level.

ROM Revision Level: Contains the revision level of drive ROM.

Number of Extents: The SQ555 supports a total of eight extents. Refer to Reserve, Release commands.

Bytes 38 through 48 are a bit-significant list of the commands supported by the SQ555, i.e., Reassign Blocks (07) a Group Zero command, corresponds to bit 0 of byte 39 where bit 7 is MSB.

Cartridge Serial Number: The drive serial number is returned in ASCII format.

SQ555 – SCSI Implementation

6.2.11 Mode Select Command Operation Code: 15H

SQ555 Parameters

Table 6-2-11. Mode Select Command

BIT BYTE	7	6	5	4	3	2	1	0
0	Operation Code							
1	Logical Unit Number			Reserved				SP
2	Reserved							
3	Reserved							
4	Parameter List Length							
5	Reserved						Flag	Link

The Mode Select Command provides a means for the Initiator to specify or change operating parameters within the SQ555.

Save Parameters (SP): If one (1), indicates that the SQ555 shall:

- Update the Current mode values with the values defined in the following Pages:
- Save all Savable Pages except the Pages defined by the Page Codes 3, and 4 which are to be saved during the next successfully completed FORMAT UNIT command.
- Then report command complete with no CHECK CONDITION status when successfully completing the above.

Savable Pages are Pages for which preceding MODE SENSE commands returned the SP bit (bit 7 byte 0) of the Page Header set to one.

If zero (0), indicates that the target shall:

- Update the Current mode values with the values defined in the following Pages.
- Shall not save the Savable Pages.
- Shall not modify the saved parameters of the Pages defined by the Page Codes 3, 4 and 5
- Then shall report command complete with no CHECK CONDITION status when successfully completing the above.

Parameter List Length: Specifies the number of bytes of Mode Select data to be transferred during the Data-Out Phase. A parameter list length of zero indicates that no data is transferred.

The Mode Select Parameter list contains a four-byte header followed by the block descriptor (if any), followed by zero or more page descriptors.

SQ555 – SCSI Implementation

Table 6-2-11-1. Mode Select Header

Mode Select Header

BIT BYTE	7	6	5	4	3	2	1	0
0	Reserved							
1	Medium Type (00)							
2	Reserved							
3	Block Descriptor Length (8)							

Medium Type (00): Default value of zero for SQ555 drive.

Block Descriptor Length: Specifies the length in bytes of all the block descriptors. It is equal to the number of block descriptors times 8 and does not include the vendor unique parameters, if any.

Block Descriptors

BIT BYTE	7	6	5	4	3	2	1	0
0	Density Code (00)							
1	Number of Blocks (MSB)							
2	Number of Blocks							
3	Number of Blocks (LSB)							
4	Reserved							
5	Block Length (MSB)							
6	Block Length							
7	Block Length (LSB)							

Density Code: Specifies the default media density. Zero is set for fixed disk drives.

Number of Blocks: Specifies the available number of blocks to be formatted. A value of zero (0), specifies the maximum number of blocks for the selected block length.

Block Length: Specifies the length in bytes of each logical block. A value of zero (0) indicates use currently formatted block length.

SQ555 – SCSI Implementation

Page Descriptors

BIT BYTE	7	6	5	4	3	2	1	0
0	Reserved		Page Code					
1	Page Length (Bytes)							
2	Refer to page definition							
n	Refer to page definition							

Each Page Descriptor supplies information regarding a particular class of functions. The page descriptors may be in any order and do not have to be supplied.

Page Code: Specifies the page code format. See table 6-2-11-2.

Page Length: Indicates the number of bytes to be associated with this page and may be zero.

Table 6-2-11-2. Page Codes

0H	Operating Parameters
1H	Error Recovery Parameters
2H	DMA Parameters
3H	Format Parameters (default only)
4H	Geometry Parameters (default only)
5H -> 1 FH	Reserved (ignored)
20H	Vendor / Product Identification
21H -> 3 FH	Reserved (ignored)

Only one set of Mode Select parameters is kept for each drive.

Table 6-2-11-3. Operating Parameters

BIT BYTE	7	6	5	4	3	2	1	0
0	Reserved		Page Code = 00h					
1	Page Length (02h)							
2	Usage	REC'Y	Status	RST-S	Reserved			
3	Device Type Qualifier (00)							

Usage: Specifies that upon overflow of the usage counters, an error be generated on the following command and that the usage counter data be saved in the sense information. Default value of zero (0) disables error presentation upon the overflow condition.

REC'Y (Recovery): Specifies that the SQ555 report all errors without attempting error recovery, correction or retry operations. Default value of zero (0) enables all normal error recovery operations.

SQ555 – SCSI Implementation

Status: Specifies that recovered error sense be reported in the event of a recoverable error, either by retry or correction. Default value of zero (0) disables recovered error sense. This bit is not applicable if retries are disabled by Recovery.

RST-S (Reset Status): Specifies that the drive shall report reset status following a bus reset. Default value of zero, enables reset status.

Device Type Qualifier: This byte may be set to further identify a device.

Page Code 01H - Error Recovery Parameter

Page Code 02H - DMA Parameters

Page Code 03H - Format parameters:(mode sense command only).
See Table 6-2-11-7.

Page Code 04H - Geometry parameters:(mode sense command only)
See Table 6-2-11-8.

SQ555 – SCSI Implementation

Table 6-2-11-4. Error Recovery Parameters

BIT BYTE	7	6	5	4	3	2	1	0
0	Reserved		Page Code = 01H					
1	Page Length (6 Bytes)							
2	0	0	TB	0	EEC	PER	DTE	DCR
3	Retry Count							
4	Reserved							
5	Reserved							
6	Reserved							
7	Reserved							

Page Code: Refer to table 6-2-11-2 for page codes descriptions.

Page Length: Indicates the number of bytes to be associated with this page and may be zero.

Transfer Block (TB): If one (1), indicates that the failing data block (recovered or unrecoverable) data will be transferred to the initiator. If zero (0), indicates that the failing data block (recovered or unrecoverable) data will not be transferred to the Initiator).

The block address reported in the REQUEST SENSE data will be of the erring block, not of the preceding block.

Enable Early Correction (EEC): If one (1), indicates that the target shall enable the use of the most expedient form of error recovery, such as error correction, before applying retries. Seek or positioning retries and the recovery procedure retries of the message system are not affected by the value of this bit. Targets implementing error correction schemes which do not provide the most expedient form of error recovery should default to zero and report the EEC bit as not changeable in the MODE SENSE Page Code 3. The EEC and DCR both of one is an invalid request, for which the target shall create the Check Condition with Illegal Request Sense Key.

If zero (0), indicates that the target shall exhaust the defined retry limit prior to enabling error correction. If DCR bit is set to one, the defined retry limit is only to be performed.

Post Error (PER): If one (1), indicates that the SQ555 shall enable the reporting of the CHECK CONDITION status for recovered errors, with the appropriate Sense Key. The CHECK CONDITION shall happen during the data transfer depending either on the DTE bit value or if an unrecoverable error occurred. If multiple errors occur, the REQUEST SENSE data will report the block address of either the last block on which recovered error occurred or of the first unrecoverable error.

If zero (0), indicates that the SQ555 shall not create the CHECK CONDITION status for errors recovered within the limits established by the other Error Recovery Flags. Recovery procedures exceeding the limits established by the other Error Recovery Flags shall be posted accordingly by the SQ555. The transfer of data may terminate prior to exhausting the Transfer Length depending on the error and the state of the other Error Recovery Flags.

SQ555 – SCSI Implementation

Disable Transfer on Error (DTE): If one (1) and if the PER bit is set to 1, indicate that the SQ555 will create the CHECK CONDITION status and terminate the data transfer to the Initiator immediately upon detection of an error. The Transfer Length is then not exhausted. The Data of the block in error, which is the first erring block encountered, may or may not be transferred to the Initiator depending upon the setting of the TB bit. The DTE bit can only be set to one by the Initiator if the PER bit is set to 1. The SQ555 will create the CHECK CONDITION status with Illegal Request Sense Key, if it receives PER bit of zero and DTE bit set to 1.

If zero (0), enables data transfer for any data which can be recovered within the limits of the Error Recovery Flags. Any erring block that would be posted, which is the last recovered block encountered, is not posted until the Transfer Length is exhausted.

Disable Correction (DCR): If one (1), indicates that error correction shall not be applied in the course of error recovery. Other normal error recovery operations are not affected by this bit. If zero (0), enables error correction.

SQ555 – SCSI Implementation

Table 6-2-11-5. Table Summary All Valid Modes of Operation

PER	DTE	DCR	DESCRIPTION
0	0	0	Retries then Correction are attempted (DCR off). Recovered and/or corrected data (if any) is transferred with no CHECK CONDITION status (PER off) at the end of the transfer. <ul style="list-style-type: none"> • Transfer Length is exhausted. Data transfer stops only if an unrecoverable error is encountered. The SQ555 will then create CHECK CONDITION status with the appropriate Sense Key. • The data of the unrecoverable Block (if any), may or may not be transferred to the Initiator depending on the setting of the Transfer Block (TB) bit. The data may not be valid data.
0	0	1	Same as (0 0 0) above but No Correction Applied (DCR on).
0	1	0	Invalid Request (DTE on, PER off)
0	1	1	Invalid Request (DTE on, PER off)
1	0	0	Report Last Data Block in error at the end of transfer. Retries then Correction (DCR off) are attempted and recovered data (if any) is transferred corrected. <ul style="list-style-type: none"> • The Transfer Length is exhausted if no unrecoverable error occurred (DTE off). • The SQ555 creates CHECK CONDITION status with RECOVERED ERROR Sense Key and reports (in the Information bytes field of the Extended Sense data) the last block for which recovered error occurred, if any (PER on). • The data of the unrecoverable Block (if any), may or may not be transferred to the Initiator depending on the setting of the Transfer Block (TB) bit. The data may not be valid data.
1	0	1	Same as (1 0 0) above but No Correction Applied (DCR on).
1	1	0	Stop Transfer on First recovered "Error Encountered. Retries then Correction (DCR off) are attempted and recovered data (if any) is transferred corrected, but transfer stops (DTE on) after the first recovered or unrecoverable error is detected. <ul style="list-style-type: none"> • The SQ555 creates CHECK CONDITION status (PER on) with RECOVERED ERROR Sense Key on the first block for which a recovered error occurred, if any. This mode will not be used if TB is set to zero.
1	1	1	Same as (1 1 0) above no Correction Applied (DCR on). <ul style="list-style-type: none"> • The data of the erring Block (if any), may or may not be transferred to the Initiator depending on the setting of the TB bit.
Retry Count:			Number of read retries. Default setting is 8.

SQ555 – SCSI Implementation

Table 6-2-11-6. DMA Parameters

BIT BYTE	7	6	5	4	3	2	1	0
0	Reserved		Page Code = 02H					
1	Page Length (Byte)							
2	Reserved							
3	Reserved							
4	DMA Timeout (0)							
5	Enable DMA Timeout							
6	Reserved							
7	Reserved							
8	Reserved							
9	Reserved							
10	Reserved							
11	Reserved							

Page Length: Specifies the number of byte to be associated with this page and may be zero.

DMA Timeout: This byte is set to zero for no DMA Timeout (default).

Enable DMA Timeout: This byte set to zero, the DMA will timeout using default time limit (460.8ms).

SQ555 – SCSI Implementation

Table 6-2-11-7. Format Parameters (Default Only)

BIT BYTE	7	6	5	4	3	2	1	0
0	Reserved		Page Code = 03H					
1	Page Length (in bytes)							

Handling of Defects Field

BIT BYTE	7	6	5	4	3	2	1	0
0	Reserved							
1	Reserved							
2	Reserved							
3	Reserved							
4	Reserved							
5	Reserved							
6	Reserved							
7	Reserved							
8	Reserved							
9	Reserved							

Track Format Field

BIT BYTE	7	6	5	4	3	2	1	0
10	Sectors per Track (MSB)						(00H)	
11	Sectors per Track (LSB)						(44H)	
12	Bytes per Physical Sector (MSB)						(01H)	
13	Bytes per Physical Sector (LSB)						(00H)	
14	Interleave (MSB)							
15	Interleave (LSB)							
16	Reserved							
17	Reserved							
18	Reserved							
19	Reserved							

Sectors per Track: This indicates the number of physical data sectors per disk track.

Bytes per Physical Sector: This indicates the number of bytes per physical sector.

Interleave: This is the same parameter passed in the Format Unit Command and is only returned by the Mode Select Command.

SQ555 – SCSI Implementation

Drive Type Field

BIT BYTE	7	6	5	4	3	2	1	0
20	0	0	RMB (1)	SURF (1)	Reserved			
21	Reserved							
22	Reserved							
23	Reserved							

Removable (RMB): A default value of one, indicates the logical unit is removable.

Surface (SURF): A default of one, indicates that the SQ555 allocates progressive addresses to all sectors on a surface prior to allocating sector addresses to the next surface.

SQ555 – SCSI Implementation

Table 6-2-11-8. Geometry Parameters (Default Only)

BIT BYTE	7	6	5	4	3	2	1	0
0	Reserved		Page Code = 04H					
1	Page Length (Bytes)							
2	Number of Cylinders (MSB)							
3	Number of Cylinders							
4	Number of Cylinders (LSB)							
5	Number of Heads							
6	Reserved							
7	Reserved							
8	Reserved							
9	Reserved							
10	Reserved							
11	Reserved							
12	Reserved							
13	Reserved							
14	Reserved							
15	Reserved							
16	Reserved							
17	Reserved							

Page Length: Indicates the number of bytes to be associated with this page and may be zero.

Number of Cylinders: Indicates the number of physical cylinders used for user data and track defect management.

Number of Heads: Indicates the number of read/write heads.

SQ555 – SCSI Implementation

Table 6-2-11-9. Vendor/Product Identification

BIT BYTE	7	6	5	4	3	2	1	0
0	Reserved		Page Code = 20H					
1	Page Length (24 Bytes)							
2-9	Vendor Identification							
10-25	Product Identification							

Page Length: Indicates the number of bytes to be associated with this page and may be zero.

Vendor Identification: These 8 bytes contains Vendor ID in ASCII.
Default value = "SyQuest"

Product Identification: These 16 bytes contains product ID in ASCII. Default value = "SQ555". The vendor identification will be returned by the Inquiry command in bytes 8-15. The product identification will be returned in bytes 16-31. The "SyQuest SQ555" default will be returned whenever a cartridge is not ready in the drive, or if page 20H has not been specified.

6.2.12 Reserve Command Operation Code: 16H

NOTE: This command is not currently supported by the SQ555.

6.2.13 Release Command Operation Code: 17H

NOTE: This command is not currently supported by the SQ555.

SQ555 – SCSI Implementation

6.2.14 Mode Sense Command Operation Code: 1AH

Table 6-2-14. Mode Sense Command

BIT BYTE	7	6	5	4	3	2	1	0
0	Operation Code							
1	Logical Unit Number			Reserved				
2	PCF		Page Code					
3	Reserved							
4	Allocation Length							
5	Reserved					Flag		Link

The Mode Sense Command provides a means for the SQ555 to report its device parameters. It is a complementary command to the Mode Select Command.

Page Control Field (PCF): Defines the type of page parameter values to be returned.

Page Code: Refer to Table 6-2-11-2 for page code function.

Allocation Length: Specifies the number of bytes that the Initiator has allocated for returned sense data. An Allocation Length of zero indicates no sense data will be transferred. This is not considered an error condition. Any other value indicates the number of bytes to be transferred. The SQ555 will terminate the data-in phase when Allocation Length bytes have been transferred or when all available sense data has been to the Initiator.

The Mode Sense data contains a four-byte header, followed by zero or more eight-byte Block Descriptors, followed by the additional drive parameters, if any.

Mode Sense Header

BIT BYTE	7	6	5	4	3	2	1	0
0	Sense Data Length							
1	Medium Type (00)							
2	WP	Reserved						
3	Block Descriptor Length							

Sense Data Length: This field specifies the length in bytes of all following data.

Medium Type: Set to zero for the SQ555.

Write Protected (WP): If one (1), indicates the drive is write protected.

Block Descriptor: Specifies the length in byte of the returned block descriptors.

SQ555 – SCSI Implementation

Block Descriptors

BIT BYTE	7	6	5	4	3	2	1	0
0	Density Code (00)							
1	Number of Blocks (MSB)							
2	Number of Blocks							
3	Number of Blocks (LSB)							
4	Reserved							
5	Block Length (MSB)							
6	Block Length							
7	Block Length (LSB)							

Density Code: Contains the default media density. Default is zero for the SQ555.

Number of Blocks: Specifies the available number of blocks to be formatted. A value of zero for number of blocks indicates that all of remaining logical blocks of the logical unit should be used as default.

Block Length: Specifies the length of logical blocks in bytes. A value of zero indicates use currently formatted block length

Page Descriptors

BIT BYTE	7	6	5	4	3	2	1	0
0	Reserved		Page Code					
1	Page Length (bytes)							
2	Refer to page definition							
n	Refer to page definition							

Page Code: See table 6-2-14-1 for page code functions.

Page Length: specifies the number of bytes to be associated with this page and may be zero.

SQ555 – SCSI Implementation

Table 6-2-14-1. Page Codes

0H	Operating Parameters (selectable)
1H	Error Recovery Parameters
2H	DMA Parameters
3H	Format Parameters (default only)
4H	Geometry Parameters (default only)
5H -> 1 FH	Reserved (ignored)
20H	Vendor / Product Identification
21H -> 3 EH	Reserved (ignored)
3FH	Report current values: All pages are returned with their currently selected or default values.

Table 6-2-14-2. Page Code Field Bit 7 and 6 Byte 2 of The CDB

7	6	Description
0	0	<p>Report Current Values</p> <ul style="list-style-type: none"> • If the Page Code is equal to 3 FH, all Pages implemented by the SQ555 will be returned to the Initiator with fields and bits set to Current values. • If the Page Code is different than 3 FH, the Page defined by the page Code, if supported will be returned with fields and bits set to Current values. <p>The Current values are either:</p> <ul style="list-style-type: none"> • as set in the last successfully completed MODE SELECT command, • or are identical to the Saved values if saving is available and if no MODE SELECT command were yet issued since the last power on, • or are identical to the Default values if no saving is available or if no Saved values are available. <p>Field and bits not supported will be set to zero. The Page Length byte value of each Page returned by the target indicates up to which field are supported within the particular Page.</p>
0	1	<p>Report Changeable Values</p> <ul style="list-style-type: none"> • If the Page Code is equal to 3 FH, all Pages implemented by the SQ555 will be returned to the Initiator with bits and fields that are allowed to be changed by the Initiator set to one. Fields and bits not allowed to be changed by the Initiator shall be set to zero. • If the Page Code is different than 3 FH, the Page defined by the Page Code, if supported will be returned to the Initiator with bits and fields that are allowed to be changed by the Initiator set to one. Fields and bits not allowed to be changed by the Initiator shall be set to zero. • If no bits or fields are changeable within a Page, the SQ555 will not return bytes 0 and 1 of the Page. • The Page Length byte value of each Page returned by the target indicates up to which field are supported within the particular page.

SQ555 – SCSI Implementation

Table 6-2-14-2. Page Code Field Bit 7 and 6 Byte 2 of The CDB (continued)

7	6	Description
1	0	<p>Report Default Values</p> <ul style="list-style-type: none"> • If the Page Code is equal to 3 FH, all Pages implemented will be returned to the Initiator with fields and bits set to the default values. • If the Page Code is different than 3 FH, the page defined by the Page Code, if supported will be returned to the Initiator with fields and bits set to the default values. • Fields and bits not supported will be set to zero. The Page Length byte value of each Page returned by the target indicates up to which field are supported within the particular page. • The value of the fields returned with this code is intended to avoid confusion over whether the value of zero is the default or the non supported value.
1	1	<p>Report Saved Values</p> <p>If the Page Code is equal to 3 FH, all Pages implemented will be returned to the Initiator with fields and bits set to the saved values if saving is supported.</p> <ul style="list-style-type: none"> • If the page Code is different than 3 FH, the Page defined by the Page Code, if that code is supported, will be returned to the Initiator with fields and bits set to the saved values if saving is supported by the target. <p>The Saved values are either:</p> <ul style="list-style-type: none"> • the values saved during the last successfully completed FORMAT UNIT or MODE SELECT commands. • or identical to the Default values if no saving possibility is available. <p>Fields and bits not supported will be set to zero. The Page Length byte value of each Page returned by the target indicates up to which field are supported within the particular page.</p> <p>Current values may be modified by successfully completed MODE SELECT commands. Saved values may only be updated by a successfully completed FORMAT UNIT command. A FORMAT UNIT command completing with No CHECK CONDITION status shall indicate that the Saved values have been successfully saved.</p> <p>An Initiator may request a particular Page to be returned by the target by selecting its code in byte two of the CDB.</p>

SQ555 – SCSI Implementation

Page Code Meaning

		No. of bytes to be returned (+ 2)					
		PCF	=	CUR	CHG	DEF	SAV
		0	0	0	1	1	0
		0	0	1	1	0	1
0H	Operating Parameters	2		2		2	2
1H	Error Recovery Parameters	6		6		6	6
2H	Disconnect/Reconnect Control Parameters	10		10		10	10
3H	Direct Access Device Format Parameter	22		0		22	22
4H	Rigid Disk Drive Geometry Parameters	16		0		16	16
5H -> 1FH	Reserved	-		-		-	-
20H	Vendor/Product ID	24		24		24	24
21H -> 3EH	Reserved	-		-		-	-
3FH	Return all Pages to the Initiator. See PCF bit configuration. Page Code valid for MODE SENSE commands only.	80		42		80	80

The SQ555 will return the same Page Length value in each Page that it supports with the 3FH Page Code whatever the value of each bit of the PCF field is.

6.2.15 Start/Stop Command Operation Code: 1BH

Table 6-2-15. Start /Stop Commands

BIT BYTE	7	6	5	4	3	2	1	0
0	Operation Code							
1	Logical Unit Number			Reserved				IMMED
2	Reserved							
3	Reserved							
4	Reserved						START	
5	Reserved					Flag	Link	

The Start/Stop Command requests the SQ555 to move the R/W heads to/from the shipping zone and stop/start the spindle.

IMMED: If one (1), indicates status shall be returned as soon as the operation is initiated. If zero (0), indicates that status shall be presented when the operation is completed.

START: If one (1), requests the drive to spin up the cartridge and position the heads at Track 0. If zero (0), requests the drive to spin down the cartridge and position the heads at the shipping zone.

SQ555 – SCSI Implementation

6.2.16 Receive Diagnostic Results Command Operation Code: 1CH

Table 6-2-16. Receive Diagnostic Results Command

BIT BYTE	7	6	5	4	3	2	1	0
0	Operation Code							
1	Logical Unit Number			Reserved				
2	Reserved							
3	Allocation Length (MSB)							
4	Allocation Length (LSB)							
5	Reserved						Flag	Link

The Receive Diagnostic Results Command requests that analysis data be sent to the Initiator after completion of a Send Diagnostic Command.

Allocation Length: Four bytes of result data, conforming to the Nonextended Sense format, will be returned regardless of the Allocation Length. The diagnostic data returned depends on the Diagnostic Command.

Following a Receive Diagnostic Result Command, a Bus Reset must be performed to return to normal operating mode.

6.2.17 Send Diagnostic Command Operation Code: 1DH

Table 6-2-17. Send Diagnostic Command

BIT BYTE	7	6	5	4	3	2	1	0
0	Operation Code							
1	Logical Unit Number			Reserved		SLFTST	0	0
2	Reserved							
3	Parameter List Length (MSB) (00)							
4	Parameter List Length (LSB) (00)							
5	Reserved						Flag	Link

The Send Diagnostic Command requests that the SQ555 perform self-diagnostic tests. There are no additional parameters for the user Send Diagnostic Command.

Self Test (SLFTST): If one (1), directs the SQ555 to complete its default self-test. If this test is requested, the Parameter List Length must be set to zero. A Receive Diagnostic Results Command, or Sense Command (preferred) is required to receive self-test results. If zero (0), this command will always return with Good Status (no operation).

NOTE: This command allows the operating system to be independent of vendor-unique diagnostic commands. The diagnostic software then becomes more portable to various operating systems. Execution of the diagnostic self-test clears any extent reservations.

SQ555 – SCSI Implementation

6.2.18 Prevent Allow Medium Removal Command Operation Code: 1EH

Table 6–2–18. Prevent/Allow Medium Removal Command

BIT BYTE	7	6	5	4	3	2	1	0
0	Prevent Allow Medium Removal							
1	Logical Unit Number			Reserved				
2	Reserved							
3	Reserved							
4	Reserved							PRVNT
5	CDS	Reserved				Flag	Link	

The Prevent/Allow Medium Removal command requests that the Target enable/disable spin down and the removal of the cartridge.

Prevent (PRVNT): If one (1), causes the SQ555 to ignore the front door button which prevents the removal of the cartridge. If zero (0), will allow testing of the door button.

Check Door Switch (CDS): If one (1), will cause the command to terminate normally regardless of the state of the door button.

CDS	PRVNT	Description
1	0	returns a Sense Key of 05H (Illegal request) with an additional Sense Code of 24H (Illegal field in CDB).
1	1	causes the command completion status to be dependent on the state of the door button. If the door button is not in the "pushed" position, the completion status will not be affected. If the door button is in the "pushed" position the command will return a Check Condition status of 02H. A Sense Status command will return a Sense Key of 06H (Unit Attention) with an Additional Sense Code of 9DH (Cartridge Change Requested).

If **PRVNT = 1** when the cartridge is already stopped, the SQ555 will return a Sense Key of 05H (Illegal request) with an additional Sense Code of 22H (Illegal function).

The prevention of medium removal condition shall terminate upon receipt of a Prevent/Allow Medium Removal command with the prevent bit set to zero, or by the receipt of a Bus Driver Reset message from any initiator or by a "hard" reset condition.

SQ555 – SCSI Implementation

6.2.19 Read Capacity Command Operation Code: 25H

Table 6-2-19. Read Capacity Command

BIT BYTE	7	6	5	4	3	2	1	0
0	Operation Code							
1	Logical Unit Number			Reserved				
2	Logical Block Address (MSB)							
3	Logical Block Address							
4	Logical Block Address							
5	Logical Block Address (LSB)							
6	Reserved							
7	Reserved							
8	Reserved							PMI
9	Reserved						Flag	Link

The Read Capacity Command provides a means for the Initiator to request information regarding the capacity of the drive.

Partial Medium Indicator (PMI): If a value of zero, indicates that the information returned in the Read Capacity Data will be the Logical Block Address and Block Length of the last logical block of the drive. The Logical Block Address in the Command Descriptor Block must be set to zero for this option.

If a value of 1, indicates that the information returned will be the Logical Block Address and Block Length of the last logical block after the Logical Block address specified in the Command Descriptor Block before a substantial delay in data transfer (e.g., a cylinder boundary).

SQ555 – SCSI Implementation

Table 6-2-19-1. Read Capacity Data

The following eight bytes of read capacity data are sent during the data-in phase of the command.

BIT BYTE	7	6	5	4	3	2	1	0
0	Logical Block Address (MSB)							
1	Logical Block Address							
2	Logical Block Address							
3	Logical Block Address (LSB)							
4	Block Length (MSB)							
5	Block Length							
6	Block Length							
7	Block Length (LSB)							

Logical Block Address: Specifies the last logical address available as requested by the PMI bit.

Block Length: Specifies the length in bytes of the logical block.

SQ555 – SCSI Implementation

6.2.20 Extended Read Command Operation Code: 28H

Table 6–2–20. Extended Read Command

BIT BYTE	7	6	5	4	3	2	1	0
0	Operation Code							
1	Logical Unit Number			Reserved				
2	Logical Block Address (MSB)							
3	Logical Block Address							
4	Logical Block Address							
5	Logical Block Address (LSB)							
6	Reserved							
7	Transfer Length (MSB)							
8	Transfer Length (LSB)							
9	INH DMA	LONG	Reserved				Flag	Link

The Extended Read Command requests that the SQ555 transfer data to the Initiator.

Logical Block Address: Specifies the Logical Block where the Read operation shall begin.

Transfer Length: Specifies the number of contiguous blocks of data to be transferred. A **transfer length of zero** indicates that no logical blocks shall be transferred. This shall not be considered an error condition. Any other value indicates the number of logical blocks to be transferred. The most recently written data value will be returned.

Inhibit DMA (INH DMA): If one (1), specifies the read operation will be performed but the data will not be sent to the Initiator. The data will be left in the drives R/W buffer. Default of zero (0), specifies the data will be sent to the Initiator.

SQ555 – SCSI Implementation

6.2.21 Extended Write Command Operation Code: 2AH

Table 6–2–21. Extended Write Command

BIT BYTE	7	6	5	4	3	2	1	0
0	Operation Code							
1	Logical Unit Number			Reserved				
2	Logical Block Address (MSB)							
3	Logical Block Address							
4	Logical Block Address							
5	Logical Block Address (LSB)							
6	Reserved							
7	Transfer Length (MSB)							
8	Transfer Length (LSB)							
9	INHDMA	LONG	Reserved				Flag	Link

The Extended Write Command requests that the SQ555 write the data transferred by the Initiator to the medium.

Logical Block Address: Specifies the Logical Block where the Write operation shall begin.

Transfer Length: Specifies the number of contiguous blocks of data to be transferred. A Transfer Length of zero indicates that no logical blocks shall be transferred. This is not considered an error condition. Any other indicates the number of logical blocks to be transferred.

The most recently written value will be returned.

Inhibit DMA (INHDMA): If one (1), specifies the write operation will be performed but the data will not be sent to the Initiator. The data will be left in the drives R/W buffer. Default of zero (0), specifies the data will be sent to the Initiator.

LONG: If one (1), specifies that the six ECC bytes will be written as part of data field (262 bytes). ECC error detection will be disabled. Only a single sector may be read in this mode. Default of zero (0), specifies the normal write operation without six ECC bytes appended to the data field (256 bytes).

SQ555 – SCSI Implementation

6.2.22 Extended Seek Command Operation Code: 2BH

Table 6-2-22. Extended Seek Command

BIT BYTE	7	6	5	4	3	2	1	0
0	Operation Code							
1	Logical Unit Number			Reserved				
2	Logical Block Address (MSB)							
3	Logical Block Address							
4	Logical Block Address							
5	Logical Block Address							
6	Reserved							
7	Reserved							
8	Reserved							
9	Reserved						Flag	Link

The Extended Seek command requests that the SQ555 seek to the specified logical block address.

SQ555 – SCSI Implementation

6.2.23 Verify Command Operation Code: 2FH

Table 6–2–23. Verify Command

BIT BYTE	7	6	5	4	3	2	1	0
0	Operation Code							
1	Logical Unit Number			Reserved			BYTCHK	0
2	Logical Block Address (MSB)							
3	Logical Block Address							
4	Logical Block Address							
5	Logical Block Address (LSB)							
6	Reserved							
7	Verification Length (MSB)							
8	Verification Length (LSB)							
9	Reserved						Flag	Link

The VERIFY command requests that the SQ555 verify the data written on the medium.

Byte Check (BYTCHK): If a value of zero, causes the verification to be simply a medium verification (CRC, ECC). If a value of one, causes a byte-by-byte compare of data on the medium and the data transferred from the initiator. If the compare is unsuccessful, the command shall be terminated with a **CHECK CONDITION** status and the sense key shall be set to **MISCOMPARE**. (BYTCHK = 1 to be implemented.)

Logical Block Address: Specifies the logical block at which the verify operation shall begin.

Verification Length: Specifies the number of contiguous logical blocks of data that shall be verified. A transfer length of zero indicates that no logical blocks shall be verified. This condition shall not be considered as an error. Any other value indicates the number of logical blocks that shall be verified.

SQ555 – SCSI Implementation

6.2.24 Read Defect Data Command Operation Code: 37H

Table 6-2-24. Read Defect Data Command

BIT BYTE	7	6	5	4	3	2	1	0
0	Operation Code							
1	Logical Unit Number			Reserved				
2	Reserved			P	G	Defect List Format		
3	Reserved							
4	Reserved							
5	Reserved							
6	Reserved							
7	Allocation Length (MSB)							
8	Allocation Length (LSB)							
9	Reserved						Flag	Link

The READ DEFECT DATA command requests that the SQ555 transfer the medium defect data to the initiator.

The meaning of bits 0 through 2 of byte 2 is similar to the bit definition of the bits 0 through 2 of the byte 1 of the FORMAT UNIT command. The initiator indicates with this field a preferred format for the defect list to be returned.

- The P bit set to one indicates that the initiator requests that the Primary list of defects be returned. The P bit of zero indicates that the drive shall not return the Primary list of defect.
- The G bit set to one indicates that the initiator requests that the Growing list of defects be returned. The G bit of zero indicates that the drive shall not return the Growing list of defects.
- With bits P and G both set to one, the drive is requested to return the primary and the growing lists of defects.
- With bits P and G both set to zero, the Defect List Header is only to be returned.

Allocation Length: Specifies the number of bytes that the initiator has allocated for returned READ DEFECT DATA. An Allocation Length of zero indicates that no READ DEFECT DATA shall be transferred. Any other value indicates the maximum number of bytes that shall be transferred. The drive will terminate the data-in phase when the Allocation Length has been transferred or when all available READ DEFECT DATA has been transferred to the initiator, whichever is less.

The READ DEFECT DATA contains a four byte header, followed by zero or more defect descriptors.

SQ555 – SCSI Implementation

The bits **P**, **G** and the **Defect List Format** indicate which defect list is actually returned. The format of the defect descriptors, if the Defect List length is different than zero, are shown in Tables 9 and 10 in the **FORMAT UNIT** command. The length of each defect descriptor may be four bytes or eight bytes depending upon the Defect List format code. The defect list length specifies the total length in bytes of the defect descriptors that follow. The Defect List Length is equal to four or eight times the number of defect descriptors.

If the Allocation Length of the CDB is too small to transfer all of the defect descriptors, the Defect List Length shall not be adjusted to reflect the truncation. The drive will not create a **CHECK CONDITION** status. It is recommended that the initiator compares the Defect List Length to the Allocation Length to ensure that it did not receive a partial list due to a too small Allocation Length.

The defect descriptors may or may not be sent in ascending order. The Initiator may be informed about the exact number of defects by dividing the Defect List Length by the Defect Descriptor Length.

Defect List Header

BIT BYTE	7	6	5	4	3	2	1	0
0	Reserved							
1	Reserved			P	G	Reserved		
2	Defect List Length (MSB)							
3	Defect List Length (LSB)							

SQ555 – SCSI Implementation

6.2.25 Write Buffer Operation Code: 3BH

Table 6-2-25. Write Buffer Command

BIT BYTE	7	6	5	4	3	2	1	0
0	3BH							
1	Logical Unit Number			Reserved			Mode	
2	00H							
3	Buffer Offset (MSB)							
4	Buffer Offset							
5	Buffer Offset (LSB)							
6	Transfer Length (MSB)							
7	Transfer Length							
8	Transfer Length (LSB)							
9	Reserved						Flag	Link

The WRITE BUFFER command is used in conjunction with the READ BUFFER command as a diagnostic function for testing target memory and the SCSI bus integrity. This command shall not alter the medium.

NOTE: The first six bytes of the R/W buffer are used for command decode (Buffer offset of zero, bytes 0 through 5). Any data written by the WRITE BUFFER command into bytes 0-5 will be over written by the next SCSI command.

The function of this command and the meaning of fields within the command descriptor block depend on the contents of the mode field. The mode field is defined as follows:

Mode	Functional Description
0 0	Combined Header and Data Supported
0 1	Vendor Unique Un-Supported
1 0	Data Un-Supported
1 1	Reserved Un-Supported

Mode 00B – Combined Header and Data:

In this mode, data to be transferred is preceded by a four-byte header. See table 6-2-25-1. The four-byte header consists of all reserved bytes. The buffer ID and the buffer offset shall be zero. The transfer length specifies the maximum number of bytes that shall be transferred during the DATA OUT phase. This number includes four bytes of header, so the data length to be stored in the drive's buffer is transfer length minus four. The initiator should attempt to ensure that the transfer length is not greater than four plus the available length that is returned in the header of the READ BUFFER command (mode 00b). If the transfer length exceeds the available length plus four, the drive will return CHECK CONDITION status and will set the sense key to ILLEGAL REQUEST.

SQ555 – SCSI Implementation

Table 6-2-25-1. Write Buffer Header

BIT BYTE	7	6	5	4	3	2	1	0
0	Reserved							
1	Reserved							
2	Reserved							
3	Reserved							

Mode 01B - Vendor Unique:

In this mode, the meaning of the buffer offset, and transfer length fields are not specified by this standard.

Mode 10B - Data:

In this mode, the Data-out phase contains buffer data. The buffer ID field shall be zero. If an unsupported buffer ID code is selected, the drive will return CHECK CONDITION status and will set the sense key to ILLEGAL REQUEST.

The buffer offset is the byte offset within the specified buffer where data shall be stored. The initiator should conform to the offset boundary requirements returned in the READ BUFFER descriptor. If the drive is unable to accept the specified buffer offset, it will return CHECK CONDITION status and it will set the sense key to ILLEGAL REQUEST.

The transfer length specifies the maximum number of bytes that shall be transferred during the DATA OUT phase to be stored in the specified buffer beginning at the buffer offset. The initiator should attempt to ensure that the transfer length plus the buffer offset does not exceed the capacity of the specified buffer. (The capacity of the buffer can be determined by the buffer capacity field in the READ BUFFER descriptor.) If the buffer offset and transfer length field specify a transfer that would exceed the buffer capacity, the drive will return CHECK CONDITION status and will set the sense key to ILLEGAL REQUEST.

Mode 11B - Reserved:

This mode is reserved for future standardization.

Buffer Offset: Is the byte offset within the specified buffer where data shall be stored. The initiator should conform to the offset boundary requirements returned in the READ BUFFER descriptor. If the target is unable to accept the specified buffer offset, it shall return a CHECK CONDITION status and it shall set the sense key to ILLEGAL REQUEST.

Transfer Length: Specifies the maximum number of bytes that shall be transferred during the DATA OUT phase to be stored in the specified buffer beginning at the buffer offset. The initiator should attempt to ensure that the transfer length plus the buffer offset does not exceed the capacity of the specified buffer. If the buffer offset and transfer length fields specify a transfer that would exceed the buffer capacity, the target shall return CHECK CONDITION status and shall set the sense key to ILLEGAL REQUEST.

SQ555 – SCSI Implementation

6.2.26 Read Buffer Operation Code: 3CH

Table 6-2-26. Read Buffer Command

BIT BYTE	7	6	5	4	3	2	1	0
0	3CH							
1	Logical Unit Number			Reserved			Mode	
2	00H							
3	Buffer Offset (MSB)							
4	Buffer Offset							
5	Buffer Offset (LSB)							
6	Allocation Length (MSB)							
7	Allocation Length							
8	Allocation Length (LSB)							
9	Reserved					Flag		Link

The Read Buffer Command returns data from the drive's internal buffer.

This command if used in conjunction with the WRITE BUFFER command as a diagnostic function for SQ555 target memory and the SCSI bus integrity. This command shall not alter the medium.

The function of this command and the meaning of fields within the command descriptor block depend on the contents of the mode field. The mode field is defined as follows:

NOTE: The first six bytes of the R/W buffer are used for command decode and may not contain valid data.

The function of this command and the meaning of fields within the command descriptor block depend on the contents of the mode field. The mode field is defined as follows:

Mode	Functional Description
0 0	Combined Read Buffer Header & Date Supported
0 1	Vendor Unique Un-Supported
1 0	Data Un-Supported
1 1	Descriptor Un-Supported

SQ555 – SCSI Implementation

Mode 00B – Combined Header and Data:

In this mode, a four-byte header followed by data bytes are returned to the initiator during the DATA IN phase. The buffer ID and the buffer offset are reserved. The allocation length specifies the maximum number of bytes that the initiator has allocated for returned header and data. An allocation length of zero indicates that no header or data shall be transferred. Any other value indicates the maximum number of bytes that shall be transferred. The drive will terminate the DATA IN phase when allocation length bytes of header plus data have been transferred or when all available header and data have been transferred to the initiator, whichever is less. The four-byte READ BUFFER header is followed by data bytes from the drive's data buffer.

Table 6-2-26-1. Read Buffer Header

BIT BYTE	7	6	5	4	3	2	1	0
0	Reserved							
1	Available Length (MSB)							
2	Available Length							
3	Available Length (LSB)							

Available Length: Specifies the total number of data bytes that are available in the drive's data buffer. This number is not reduced to reflect the allocation length nor is it reduced to reflect the actual number of bytes written using the WRITE BUFFER command. Following the READ BUFFER header, the drive will transfer data from its data buffer. The number of data bytes transferred following the READ BUFFER header shall be the lesser of allocation length minus four or available length.

Mode 01B – Vendor Unique:

In this mode, the meaning of the buffer ID, buffer offset, and allocation length fields are not specified by this standard.

Mode 10B – Data:

In this mode, the DATA IN phase contains buffer data. The buffer ID field shall be zero. If an unsupported buffer ID code is selected, the drive will return CHECK CONDITION status and will set the sense key to ILLEGAL REQUEST.

The buffer offset is the byte offset within the specified buffer where data shall be stored. The initiator should conform to the offset boundary requirements returned in the READ BUFFER descriptor. If the drive is unable to accept the specified buffer offset, it will return CHECK CONDITION status and it will set the sense key to ILLEGAL REQUEST.

Mode 11B – Descriptor:

In this mode, a maximum of four bytes of READ BUFFER descriptor information are returned. The drive will return the descriptor information for the buffer specified by the buffer ID. If there is no buffer associated with the specified buffer ID, the drive will return all zeros in the READ BUFFER descriptor.

The buffer offset is reserved in this mode. The allocation length should be set to four or greater. The drive will transfer the lesser of allocation length or four bytes of READ BUFFER descriptor. The READ BUFFER descriptor is defined as shown in Table 6-2-26-2.

SQ555 – SCSI Implementation

Table 6-2-26-2. Read Buffer Descriptor

BIT BYTE	7	6	5	4	3	2	1	0
0	Offset Boundary (FFH)							
1	Buffer Capacity (MSB)							
2	Buffer Capacity							
3	Buffer Capacity (LSB)							

The offset boundary returns FFH indicating a zero boundary alignment within the buffer.

The buffer capacity field will return the size of the selected buffer in bytes.

Buffer Offset: Is the byte offset within the specified buffer where data shall be stored. The initiator should conform to the offset boundary requirements returned in the READ BUFFER descriptor. If the target is unable to accept the specified buffer offset, it shall return a CHECK CONDITION status and it shall set the sense key to ILLEGAL REQUEST.

Transfer Length: Specifies the maximum number of bytes that shall be transferred during the DATA OUT phase to be stored in the specified buffer beginning at the buffer offset. The initiator should attempt to ensure that the transfer length plus the buffer offset does not exceed the capacity of the specified buffer. If the buffer offset and transfer length fields specify a transfer that would exceed the buffer capacity, the target shall return CHECK CONDITION status and shall set the sense key to ILLEGAL REQUEST.

SQ555 – SCSI Implementation

6.3 SENSE KEY AND ERROR CODE DESCRIPTORS

6.3.1 Sense Keys

Table 6-3-1. Sense Keys (0-7)

Sense Key	Description
0H	NO SENSE: indicates that there is no specific Sense Key information to be reported for the designated unit.
1H	RECOVERED ERROR: indicates that the last command was successfully completed, with some recovery action performed by the drive. Details can be determined by examining the Additional Sense bytes and the Information bytes.
2H	NOT READY: indicates that the drive cannot be accessed. Operator intervention may be required to correct this condition.
3H	MEDIUM ERROR: indicates that the command terminated with a non-recovered error condition which was probably caused by a flaw in the medium, or an error in the recorded data.
4H	HARDWARE ERROR: indicates that the drive detected a non-recoverable hardware failure (controller failure, device failure, etc.) while performing the command, or during a self-test.
5H	ILLEGAL REQUEST: indicates that there was an illegal parameter in the Command Descriptor Block or in the additional parameters supplied as data for some commands.
6H	UNIT ATTENTION: indicates that a reset has occurred since the last selection by this initiator.
7H	DATA PROTECT: Indicates that a WRITE operation was attempted on a "WRITE PROTECTED" cartridge.
8H	BLANK CHECK: not supported
9H	VENDOR UNIQUE: reserved
AH	COPY ABORTED: not supported
BH	ABORTED COMMAND:
CH	EQUAL: not supported
DH	VOLUME OVERFLOW: not supported
EH	MISCOMPARE: not supported
FH	This Sense key is reserved

SQ555 – SCSI Implementation

6.3.2 Error Codes

Table 6-3-2. Additional Sense Codes

Byte12 Additional Sense Codes		
00H	No Additional Sense Information	No sense
01H	No Index/Sector Signal	Hardware Error
02H	No Seek Complete	Hardware Error
03H	Write Fault	Hardware Error
04H	Drive Not Ready	Not ready
05H	Drive Not Selected	Not ready
06H	No Track Zero Found	Hardware Error
07H	Multiple Drives Selected	Hardware Error
08H - > 0FH	Reserved	
10H	ID CRC or ECC Error	Hardware Error/ Medium Error
11H	Unrecovered Read Error of data blocks	Medium Error
12H	No Address Mark found in ID field	Medium Error
13H	No Address Mark found in Data field	Medium Error
14H	No record found	Medium Error
15H	Seek Error (wrong track address found)	Hardware Error/ Medium Error
16H	Recovered Data Address Mark	Medium Error
17H	Recovered Read data with target's Read retries (not with ECC)	Recovered Error
18H	Recovered Read data with target's ECC correction (not with retries)	Recovered Error
19H	Defect List Error	Medium Error
1AH	Parameter Overrun	Illegal Request
1BH	Reserved	Hardware Error
1CH	Primary Defect List not found	Medium Error or Illegal Request
1DH	Reserved	Miscompare
1EH	Reserved	Medium Error
1FH	Reserved	
20H	Invalid Command Operation Code	Illegal Request
21H	Illegal Logical Block Address. Address greater than the LBA returned by the Read Capacity data with PMI not set	Illegal Request
22H	Illegal function for device type	Illegal Request
23H	Reserved	
24H	Illegal field in CDB	Illegal Request
25H	Invalid LUN	Illegal Request
26H	Invalid field in Parameter List	Illegal Request
27H	Write Protected	Hardware Error
28H	Medium Changed	Unit Attention
29H	Power on or Reset or Bus Device Reset occurred	Unit Attention
2AH	Reserved	Unit Attention
2BH - > 2FH	Reserved	
30H	Incompatible Cartridge	Medium Error
31H	Format Failed	Medium Error
32H	No Defect Spare Location Available	Medium Error
33H - > 3FH	Reserved	

SQ555 – SCSI Implementation

Table 6-3-2. Additional Sense Codes (continued)

Byte12 Additional Sense Codes		
40H	RAM failure	Hardware Error
41H	ECC diagnostic failure	Hardware Error
42H	Reserved	Hardware Error
43H	Message Reject Error	
44H	SCSI Hardware/Firmware Error	Hardware Error
45H	Select/Reselect failed	Hardware Error
46H	Unsuccessful Soft Reset	
47H	Parity Error	
48H	Initiator Detected Error	
49H	Inappropriate/Illegal Message	
4AH - > 4FH	Reserved	
50H - > 5FH	Reserved	
60H - > 6FH	Reserved	
70H	Self Test Failed	Hardware Error
71H	Check Sum Failed	Hardware Error
72H	Internal RAM Failed	Hardware Error
73H	External RAM Failed	Hardware Error
74H	SERDES Functional/RAM Test Failed	Hardware Error
75H	R/W Buffer Test Failed	Hardware Error
76H	Red-Amber/Green LEDs Failed	Hardware Error
77H - > 7FH	Reserved	
80H - > 8FH	Reserved	
90H	Data Check in Retry MOde	
91H	Reserved	
92H	Interleave Error	
93H	Bad Format on Drive	
94H	Volume Overflow	
95H	Command Parity Error	
96H	Mode Sense Not Sense	
97H	Wrong Head in ID	
98H	Wrong Cylinder in ID	
99H	DMA Timeout	
9AH	Write Timeout	
9BH	Fine Track Status Flag	
9CH	Error Counter Overflow	
9DH	Cartridge Change Requested	
9EH	Compare Error During Verify	
9F - > FFH	Reserved	

SQ555 – Maintenance

SECTION 7 SQ555 MAINTENANCE

The SQ555 disk drive does not require a scheduled Preventive Maintenance (PM) cycle. The drive may or may never need to be cleaned. The environment and the user handling would determine the necessity of a cleaning cycle.

NOTE: Always store the SQ400 data cartridge in the supplied protective cartridge case.

7.1 CLEANING REQUIREMENT

The SQ555 spindle motor hub should be cleaned when the front panel AMBER/RED LED continues to flash intermittently during the period the SQ555 disk drive is in an idle running mode (computer is not accessing the drive). This flashing AMBER/RED LED indicates the drive is having a problem aligning the READ/WRITE heads on the recording track. This can be caused as a result of dirt on the spindle motor hub which prevents the SQ400 cartridge from seating properly on the spindle motor hub. See FIGURE 7-1.

NOTE: This is the only cleaning required.

CAUTION

NO ATTEMPT SHOULD BE MADE TO CLEAN THE READ/WRITE HEADS AND/OR SQ400 CARTRIDGE DISKS. DO NOT BLOW AIR INTO THE DISK DRIVE AND/OR CARTRIDGE.

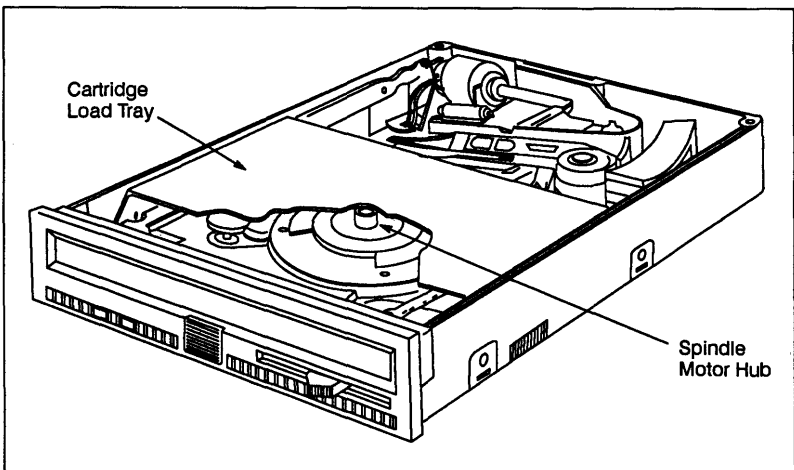

Figure 7-1. Spindle Motor Hub

7.2 CLEANING EQUIPMENT

Use the SyQuest cleaning cartridge (C-CART) kit P/N 58061-001 for cleaning the SQ555 disk drive's spindle motor hub.

SQ555 – Maintenance

7.2.1 The C-Cart Kit Contains The Following Items:

1. Cleaning Cartridge (C-CART); Red plastic cartridge P/N 90126-001.
2. Clean replaceable foam pads (C-FOAM) kit P/N 58109-001 (Re-order item).
3. C-CART Instruction Booklet P/N 58083-001.

In addition to the C-CART kit, there is other item that user must supply:

1. Freon-Mallincrodt #2857 (112 Trichloro - 122 Trifluoromethane)

CAUTION

NO OTHER CLEANING AGENT IS RECOMMENDED, OTHERWISE
SQ555 DISK DRIVE WARRANTY WILL NOT BE VALID.

7.3 CLEANING PROCEDURE

1. Place a clean C-FOAM on the mounting in the center of the C-CART (if one is not already in place).

7.3.1 C-FOAM Should Be Replaced Approximately Every 10 Insertions Of The C-CART And/Or When Visually Dirty.

- a. Insure the adhering surface of the C-CART is clean of all glue and debris.
- b. Remove the paper back from the new C-FOAM.
- c. Affix the new C-FOAM glue surface toward the C-CART. See FIGURE 7-2.

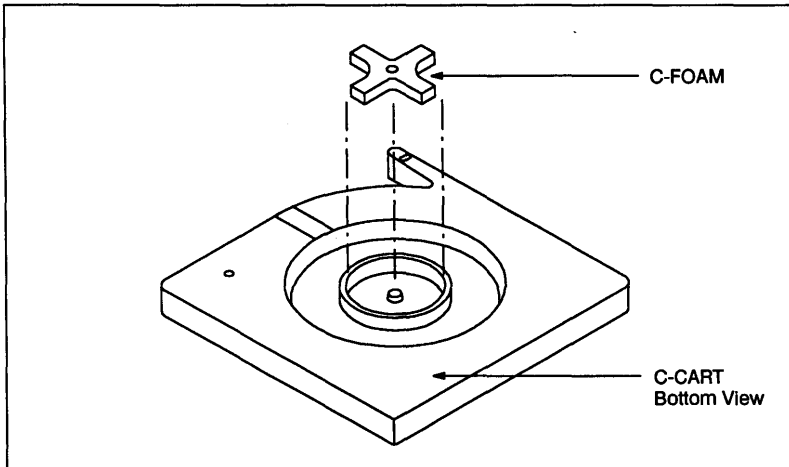

Figure 7-2. C-FOAM Installation

SQ555 – Maintenance

2. Apply two to three drops of Freon-TF to the C-FOAM. See FIGURE 7-3.

NOTE: C-FOAM should be moist but not soaked.

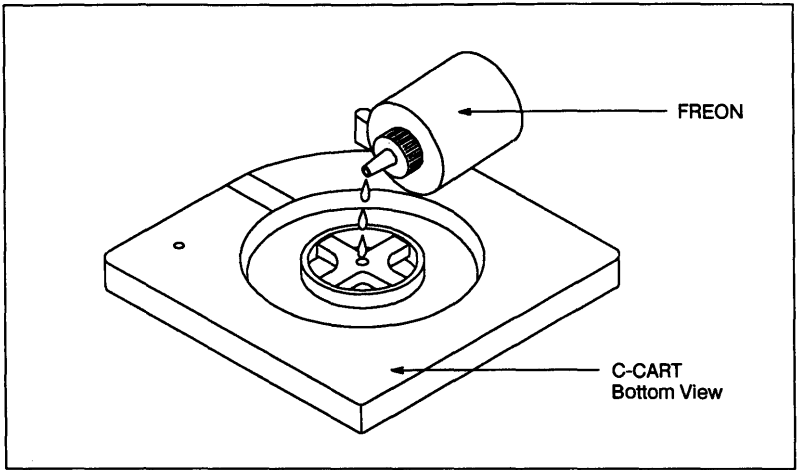

Figure 7-3. Cleaning Fluid Application Procedure

3. Insert the C-CART (C-FOAM facing toward the stop button/cartridge load lever) into the drive. See FIGURE 7-4.

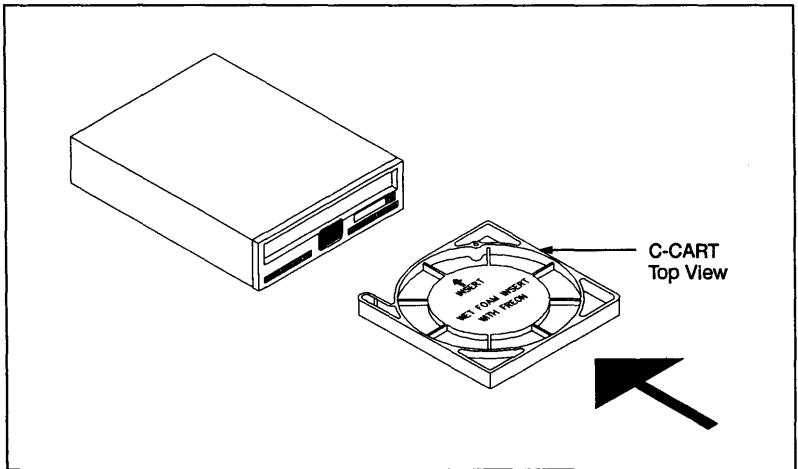

Figure 7-4. C-CART Installation Procedure

SQ555 – Maintenance

4. Push the cartridge load lever to the left until flush with the front panel and wait 5 seconds. See Section 2.4.1, page 2-2 for inserting the cartridge.
5. Press the cartridge stop button and follow the procedures in Section 2.4.2, page 2-4 for removing the cartridge.
6. Insure the SQ400 cartridge's disk hub is clean and free from contaminants.
7. Proceed with the normal operating procedures with the SQ400 data cartridge in verifying that the fault has been eliminated.

NOTE: If cleaning the spindle motor hub with the C-CART does not stop the intermittent AMBER/RED LED from flashing, then the following steps should be taken.

- a. Try another SQ400 data cartridge to validate the integrity of the original cartridge.
- b. Additional cleaning of the SQ555 disk drive spindle motor hub may be required.
- c. If the fault symptom still exist after performing the two steps above, return the SQ555 disk drive to your authorized supplier for repair (follow your supplier's return material authorization policy).

SQ555 – Technical Specifications

APPENDIX A TECHNICAL SPECIFICATIONS

Technical specifications for the SQ555 disk drive and the SQ400 cartridge are listed in Table A-1.

Table A-1. Technical Specifications

Unformatted Capacity*

	Data Bytes per	Sectors per	Tracks per	Surfaces per
Sector	314*	--	--	--
Track	21,350	68	--	--
Surface	27,392,050	86,700	1,275	--
Cartridge	54,784,100	173,400	2,550	2

*Of the 1283 physical tracks per surface, 4 are reserved for use as spares, and 4 are used as maintenance tracks.

Formatted Capacity

	Data Bytes per	Sectors per	Tracks per	Surfaces per
Sector	256	--	--	--
Track	17,408	68	--	--
Surface	22,334,464	86,700	1,275	--
Cartridge	4,668,928	173,400	2,550	2

Bytes per Sector	256	512	1024
Sectors per track	68 + 2 spare	34 + 1 spare	17

Read/Write Heads: 2

Data Error Rate*

Recoverable: Less than one (1) in 10^{10} bits read

Non-Recoverable: Less than one (1) in 10^{12} bits read

*With retries and ECC enabled (disk drive is operated within the specified environmental limits).

Interface

Industry standard SCSI. (ANSI X3.131-1986) Controller features include the following:

Controller Buffer Size: 8 Kbytes
Controller Buffer Type: Dual-ported
Interleave: 1:1

SQ555 – Technical Specifications

Seek Time

Single cylinder seek (average):	7 ms
Random seek (average)*:	20 ms
Maximum seek (1275 cylinders):	42 ms
Head switch time:	5 ms

*Average random seek time is defined as the time established by averaging one-third stroke seeks.

Latency Time

Average: 9.32 ms \pm 0.5%

Data Transfer Rate

Internal (Controller/Disc):

Burst:	10 megabits per second (1.25 MBytes/sec)
Sustained:	>4.8 megabits per second (> 600 KBytes/sec)

External (Host/Controller):

Asynchronous Burst:	10 megabits per second
Sustained:	>4.8 megabits per second

Flaw Handling (Sector Sparing)

The SQ555 flaw handling during the SCSI FORMAT COMMAND uses three methods as follows:

1. SECTOR SLIP

When a flawed sector is found and a spare exists on the same track, the flawed sector and all following sectors on that track will be slipped by one sector. The limit is two sectors per track. Additional flaws will be handled by alternate assignment or by track slipping.

2. ALTERNATE ASSIGNMENT

When a flawed sector is found and no spare exists on the same track, the flawed sector will be reassigned to the closest spare sector. The search will begin by checking four tracks in both directions on the same head, after which all tracks of both heads will be searched until a spare location is found. The search is limited to valid data tracks.

3. SLIPPED TRACKS

When more than six flaws are found on a single track, then that track and all following tracks of the same head are slipped by one track. There are eight spare tracks at the four innermost cylinders of the disk. All eight spare tracks may be used for either head.

The SCSI REASSIGN BLOCK command will only use the alternate assignment method in order to preserve the data of all other sectors. If the cartridge is reformatted and the option is specified to use manufacturing and user flaws, then any alternate assignments will be converted to slipped sectors if possible.

The total number of all flaws is limited to 100 slips or reassignments and 8 slipped tracks.

SQ555 – Technical Specifications

Seek Error Rate

Less than one (1) seek error in 10^6 seeks when the drive is operated within the specified environmental limits.

Disc Speed

3220 rpm + 0.5%

Tracks

The track usage on the SQ400 cartridge has been allocated to where the first 34 tracks define the outer guard band tracks and the last 60 tracks establish the inner guard band. There are a total 1,283 data tracks, of these 1,275 are the primary data tracks and the remaining are used for alternate track assignments and as maintenance tracks.

Recording Density

Innermost Track: 15,761 flux reversals/in. (620.51 flux reversals/mm)
23,642 bits/in. (930.79 bits/mm)

Track Density

1,086 tracks/in. (42.76 tracks/mm)

Coding System

2-7 Run Length Limited Code (RLL)

Write Clock Frequency

20.0 MHz + .05%

Bit Cell Time

50.0 ns (2-7 RLL)

Discs

OD: 5.118 in. (130 mm)
ID: 1.575 in. (40 mm)

Power Supply Ratings

Voltage	Max. Ripple	Max. Current Running	Max. Current Spin-Up
+ 12 VDC \pm 10%	100 MV P-P	1.7 A	2.0 A
+ 5 VDC \pm 5%	100 MV P-P	0.8 A	0.8 A

DC Power Requirements

Power Dissipation	Typical	Maximum
Spin-up	24.8 Watts	28.0 Watts
Running	22.0 Watts	24.0 Watts

SQ555 – Technical Specifications

Acoustical Noise

< 50 dbA sound power level

Safety

- UL 478
- CSA C22.2 No. 0-M1982 Part II and No. 220-M1986
- TVU DIN IEC 380/VDE 0806 /8.81
- VDE 0871
- FCC complies with the limits for a Class B computing device, subpart J of Part 15 of FCC rules.

WARNING

Only devices certified to comply with the Class B limits may be attached to this peripheral. The manufacturer is not responsible for any radio or TV Interference caused by unauthorized modification to this equipment. Only devices certified to comply with the Class B Limits may be attached to this peripheral.

Physical Characteristics

	SQ555 DISK DRIVE	SQ400 CARTRIDGE
Weight:	<2.75 Lbs. (<1.25 kg)	<0.45 Lbs. (<0.2 kg)
Width:	5.75 in. (146.6 mm)	5.4 in. (137.7 mm)
Length:	8.03 in. (204 mm)	5.4 in. (137.7 mm)
Height:	1.63 in. (41.6 mm)	0.5 in. (12.75 mm)

Reliability and Maintenance

Mean Time Between Failures: 30,000 power-on-hours, typical usage.

Service Life Objectives:

The SQ555 disk drive is designed and constructed to provide an operating life of 5 years, or 10,000 cartridge (SQ400) insertions/power up/power down cycles.

Maintenance Objectives:

The SQ555 disk drive does not require a scheduled preventive maintenance cycle. The environment and the user handling may determine the necessity of a cleaning cycle.

Mean Time To Repair: Less than 30 minutes (drive considered as a complete replaceable unit).

SQ555 – Environmental Requirements

APPENDIX B ENVIRONMENTAL REQUIREMENTS

The environmental requirements for the SQ555 disk drive and the SQ400 are listed in Table B-1.

NOTE: The SQ555 disk drive and the SQ400 cartridge must be operated within the environmental limits specified in order for them to function properly.

Table B-1. Environmental Requirements

Temperature

Operating: 5 to 50°C (41 to 122°F)

■ Non-operating: -40 to 70°C (-40 to 158°F)

Maximum rate of change shall not exceed 10°C (18°F) per hour.

Relative Humidity*

Operating: 8% to 80%

Nonoperating: 5% to 90%

Maximum West Bulb 32°C (90°F)

*Excludes all conditions which can cause condensation in or on the disk drive and/or in the cartridge.

Altitude

■ Operating: 1,000 ft. (305 m) below sea level to 10,000 ft. (3,048 m) above sea level.

■ Nonoperating (packaged): 1,000 ft. (305 m) below sea level to 40,000 ft. (12,210 m).

Shock (on mounting frame and front panel)

Drive and Cartridge

Operating: 11 ms, half wave sine shock with a peak amplitude of 2.0 g's without loss of data and 5 g's with no physical damage.

Drive (without cartridge)

Nonoperating: 10 ms, half sine shock with peak amplitude of 40 g's.

Cartridge

Nonoperating: The SQ400 cartridge shall withstand a 30 inch drop to a vinyl tile covered concrete floor; without physical damage or occurrence of nonrecoverable data errors, or long term degradation of performance characteristics.

Cartridge inside protective SyQuest case shall withstand a 48 inch drop to meet same shock resistant characteristics as above.

SQ555 – Environmental Requirements

Vibration (sweep rate of 1 octave/min.)

Operating**:	5–8.2hz	0.036 inch double amplitude
	8.2–500hz	0.25g peak to peak
	500–8.2hz	0.25g peak to peak
	8.2–5hz	0.036 inch double amplitude

**Without loss of data

Nonoperating:	2.7hz	0.4 inch double amplitude
	7–500hz	2.0g peak to peak amplitude
	500–7hz	2.0g peak to peak amplitude
	7–2hz	0.4 inch double amplitude

EMI Susceptibility

100dB microvolt/meter from 30 to 200 MHz

Electro Static Discharge

10KV – no error rate degradation

20KV – no component failure

SQ555 – Read/Write Timing Diagrams

APPENDIX C READ/WRITE TIMING DIAGRAMS

This appendix contains the timing diagrams for the Read and Write commands.

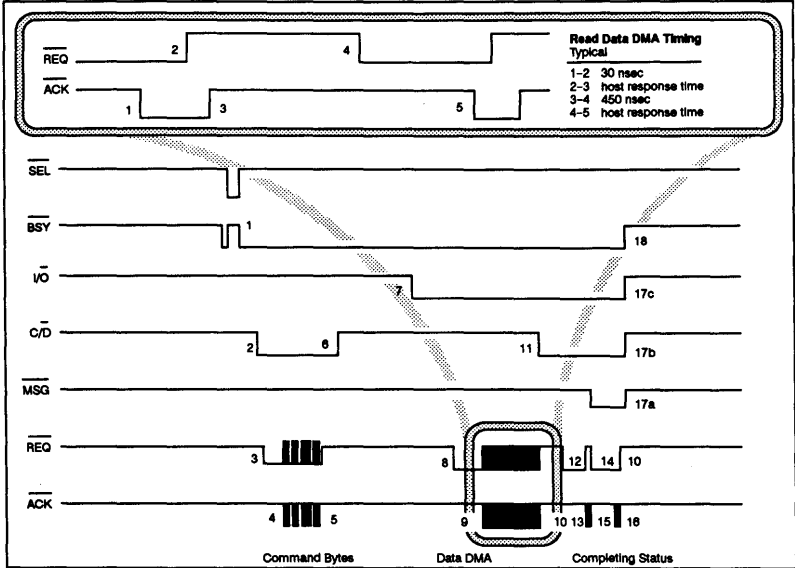

Figure C-1. Read Timing Diagram

SQ555 – Read/Write Timing Diagrams

NOTES ON THE READ COMMAND TIMING DIAGRAM

Table C-1 lists the timing transients between the points specified on the diagram.

Table C-1. Read Timing Diagram Timing Transients

Point	Time Transient (typical)
1-2	102 micro sec.
2-3	24 micro sec.
5-6	147 micro sec.
6-7	395 micro sec.
7-8	time to find and read sector
8-9	host response time
10-11	130 micro sec.
11-12	47 micro sec.
12-13	host response time
13-14	34 micro sec.
14-15	38 micro sec.
15-16	host response time
16-17a-c	46 micro sec.
17a-c-18	5 micro sec.

SQ555 – Read/Write Timing Diagrams

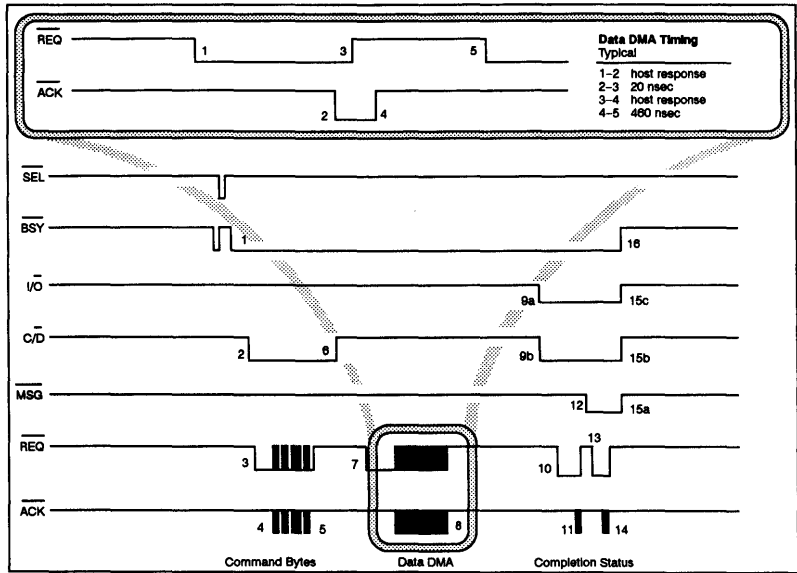

Figure C-2 Write Timing Diagram

SQ555 – Read/Write Timing Diagrams

NOTES ON THE WRITE COMMAND TIMING DIAGRAM

Table C-2 lists the timing transients between the points specified on the diagram.

Table C-2. Write Timing Diagram Timing Transients

Point	Time Transient (typical)
1-2	105 micro sec.
2-3	24 micro sec.
3-4	host response time
5-6	150 micro sec.
6-7	475 micro sec.
8-9a	time to find and write sector
9a-b-10	47 micro sec.
10-11	host response time
11-12	35 micro sec.
12-13	38 micro sec.
13-14	host response time
14-15a-c	46 micro sec.
15a-c-16	5 micro sec.

SQ555 – SCSI Electrical Specification

APPENDIX D SCSI ELECTRICAL SPECIFICATION

The SQ555 electrical consists of a SCSI bus and a power cable. The SCSI bus is connected to the SQ555 by an ANSI standard SCSI signal, connector and cable.

D.1 SCSI BUS SIGNALS

There are nine (9) control signals and nine data signals on J2 a 50 pin connector. Table D-1 lists the SCSI signals and their pin assignments.

Table D-1. SCSI Bus Signals

<u>Signals</u>	<u>J2-Pin</u>	
Busy (BSY):	36	An "or-tied" signal which indicates that the bus is in use.
Select (SEL):	44	A signal used by an Initiator to select the SQ555 or by the drive to reselect an Initiator.
Control/Data (C/D):	46	A signal driven by the SQ555. It indicates whether Control or Data information is on the data bus. True indicates Control.
Input/Output (I/O):	50	A signal driven by the SQ555 which controls the direction of data flow on the data bus, with respect to an Initiator. True indicates input to the Initiator.
Message (MSG):	42	A signal driven by the SQ555 during the message phase.
Request (REQ):	48	A signal driven by a target to indicate a request for a REQ/ACK data transfer handshake.
Acknowledge (ACK):	38	A signal driven by an Initiator to indicate an acknowledgement for a REQ/ACK data transfer handshake.
Attention (ATN):	32	A signal driven by an Initiator to indicate the attention condition.
Reset (RST):	40	An "or-tied" signal which indicates the reset condition.
Data 0-7	2-16 (even)	The data lines.
Data Parity	18	An odd parity bit for the data lines.

Note: Except pins 25 and 26 which are left open, all odd pins and even Pins 20, 22, 24, 28, 30, and 34 are connected to ground. All signals are low true.

SQ555—SCSI Electrical Specification

D.1.2 Signal Characteristics

Signals may assume either true or false values (see Table D-1-2). There are two methods of driving these signals. In both cases, the signal must be actively driven true.

In the case of the "or-tied" drivers, the driver does not drive the signal to the false state, instead, the bias circuitry of the 220/300 bus terminators pulls the signal false whenever it is "released" (not driven by the drivers at every drive).

In the case of the "non or-tied" driver, the signal may be actively driven false, or the bias circuitry will pull it false when the signal is "released".

The BSY and RST signals are "or-tied". In the ordinary operation of the bus, these signals are simultaneously driven true by several drivers. No other signals are simultaneously driven by two or more drivers. Any signals, other than BSY and RST, may employ "or-tied" or "non or-tied" drivers. There is no operational problem in mixing "or-tied" or "non or-tied" drivers on the same signal.

Table D-1-2. Signal Levels

	<u>Input Voltage</u>	<u>Input Current</u>	<u>Output Voltage</u>	<u>Output Current</u>
True	0.0-0.8 VDC	-0.4A	0.0-0.4 VDC	48 MA
False	2.0 V-5.25 VDC	---	2.5-5.25 VDC	---

Note: Input current with terminators is + 22 MA max.

D.2 SCSI SIGNAL SOURCES

Table D-2 indicates which type of device is allowed to source each signal. No attempt is made to show if this source is driving asserted, non-asserted or passive. All device drivers that are not active sources shall be in the passive state. Note that the RST signal may be sourced by any device.

Table D-2. Signal Sources

BUS PHASE	BSY	SEL	C/D,I/O MSG,REQ	ACK/ATN	DB(7-0,P)
Bus Free	None	None	None	None	None
Arbitration	All	Winner	None	None	SCSI ID
Selection	I&D	Initiator	None	Initiator	Initiator
Reselection	I&D	Drive	Drive	Initiator	Drive
Command	Drive	None	Drive	Initiator	Initiator
Data In	Drive	None	Drive	Initiator	Drive
Data Out	Drive	None	Drive	Initiator	Initiator
Status	Drive	None	Drive	Initiator	Drive
Message In	Drive	None	Drive	Initiator	Drive
Message Out	Drive	None	Drive	Initiator	Initiator

SQ555 – SCSI Electrical Specification

- ALL:** The signal shall be driven by all drives that are actively arbitrating.
- SCSI ID:** A unique data bit (the SCSI ID) must be driven by each SCSI drive that is actively arbitrating. The other seven data bits must be released, i.e., not driven by this device.
- I & T:** The signals are driven by the Initiator and/or the SQ555 as specified in the Arbitration and Selection phases.
- INITIATOR:** If this signal is driven, it may only be driven by the active Initiator.
- NONE:** This signal must be released, i.e., not driven by any SCSI device. The bias circuitry of the bus terminator pulls the signal to the false state.
- WINNER:** This signal must be driven by the one drive that wins Arbitration.
- TARGET:** If this signal is driven, it will be driven only by an active SQ555.

D.3 SCSI BUS TIMING

Unless otherwise indicated, the delay time measurements for each drive shall be calculated from signal conditions existing at that drive's own SCSI bus connection. Normally, these measurements need not consider delays in the cable.

D.3.1 Arbitration Delay

The minimum time that a device will wait from asserting BSY for arbitration until the data bus can be examined for an arbitration win. The SQ555's arbitration delay is 20 microsec. min. and the initiator's delay is 2.2 microsec. min., no max.

D.3.2 Assertion Period

The minimum time that a SQ555 will assert REQ while using synchronous data transfers is also 20–30 nsec. Also, the minimum time that an Indicator will assert ACK while using synchronous data transfers is 90 ns.

D.3.3 Bus Clear Delay

The maximum time for a device to stop driving all bus signals after:

1. BUS FREE phase is detected (BSY and SEL both false for a Bus Settle Delay).
2. Select is received from another drive during Arbitration phase.

The Bus Clear Delay is 800 nsec. for an initiator.

NOTE: For the first condition above, the maximum time for a device to clear the bus from BSY and SEL first becoming false is 1200 nsec. for an Initiator. If a device requires more than a Bus Settle Delay to detect Bus Free, it shall clear the bus within a Bus Clear Delay minus the excess time.

D.3.4 Bus Free Delay

The maximum time for a device to assert BSY and its SCSI ID bit on the data bus after it detects Bus Free phase (BSY and SEL both false for a Bus Settle Delay) for the purpose of entering Arbitration phase. The Initiator's Delay is 400 nsec.

SQ555 – SCSI Electrical Specification

D.3.5 Bus Set Delay

The maximum time for a device to assert BSY and its SCSI ID bit on the data bus after it detects Bus Free phase (BSY and SEL both false for a Bus Settle Delay) for the purpose of entering Arbitration phase. The Bus Set Delay is 1.8 microsec. for an Initiator.

D.3.6 Bus Settle Delay

The time to wait for the bus to settle after changing certain control signals.

D.3.7 Cable Skew Delay (10 nsec. max.)

The maximum difference in propagation time allowed between any two SCSI bus signals when measured between any two devices.

D.3.8 Data Release Delay (400 nsec. max.)

The maximum time for an initiator to release the data bus signals following the transition of the I/O signal from false to true.

D.3.9 Deskew Delay (45 nsec. min.)

The minimum time required for deskew of certain signals.

D.3.10 Reset Hold Time (25 microsec. min., no max.)

The minimum time for which RST is asserted.

D.3.11 Selection Abort Time

The maximum time that a Drive/Initiator will take from its most recent detection of SEL or reselect until asserting a BSY response. This timeout is required to ensure that a Drive/Initiator does not assert BSY after a selection/reselection phase has been aborted. The SQ555's Abort Time is 18 microsec. and the Initiator's Abort Time is 200 microsec. max.

D.3.12 Selection Timeout Delay

The minimum time that a device should wait for a BSY response during the selection/reselection phase before starting the timeout procedure. The SQ555's Timeout Delay is 250 msec. and for the Initiator it is 250 msec.



SyQuest
TECHNOLOGY

47923 Warm Springs Blvd.
Fremont, CA 94539-7494
(415) 438-5550
FAX: (415) 651-3338